

Skeleta of affine hypersurfaces

HELGE RUDDAT
 NICOLÒ SIBILLA
 DAVID TREUMANN
 ERIC ZASLOW

A smooth affine hypersurface Z of complex dimension n is homotopy equivalent to an n -dimensional cell complex. Given a defining polynomial f for Z as well as a regular triangulation \mathcal{T}_Δ of its Newton polytope Δ , we provide a purely combinatorial construction of a compact topological space S as a union of components of real dimension n , and prove that S embeds into Z as a deformation retract. In particular, Z is homotopy equivalent to S .

14J70; 14R99

1 Introduction

The Lefschetz hyperplane theorem is equivalent to the assertion that a smooth affine variety Z of complex dimension n has vanishing homology in degrees greater than n . A stronger version of this assertion is attributed to Thom in the work of Andreotti and Frankel [4]: Z actually deformation retracts onto a cell complex of real dimension at most n . We will borrow terminology from symplectic geometry and call a deformation retract with this property a *skeleton* for Z . The purpose of this paper is to investigate the combinatorics of such skeleta for affine hypersurfaces $Z \subseteq \mathbb{C}^{n+1}$, and a more general class of affine hypersurfaces in affine toric varieties. For any such hypersurface, we give a combinatorial recipe for a large number of skeleta.

By “combinatorial” we mean that our skeleton makes contact with standard discrete structures from algebraic combinatorics, such as polytopes and partially ordered sets. Before explaining what we mean in more detail, let us recall for contrast Thom’s beautiful Morse-theoretic proof of Lefschetz’s Theorem, which provides a recipe of a different nature. Fix an embedding $Z \subseteq \mathbb{C}^N$, and let $\rho: Z \rightarrow \mathbb{R}$ be the function that measures the distance to a fixed point $P \in \mathbb{C}^N$. For a generic choice of P , this is a Morse function, and since it is plurisubharmonic, its critical points cannot have index larger than n . Thom’s skeleton is the union of stable manifolds for gradient flow of ρ .

This recipe reveals many important things about the skeleton (most important among them that the skeleton is *Lagrangian*, a point that has motivated us but plays no role in this paper). The proof also works in the more general context of Stein and Weinstein manifolds; see eg Cieliebak and Eliashberg [8]. However, finding an explicit description of these stable manifolds requires one to solve some fairly formidable differential equations. In this paper, we avoid this difficulty by defining a skeleton through a simple, combinatorial construction.

One might expect a rich combinatorial structure to emerge from the theory of Newton polytopes for hypersurfaces. The situation is simplest for hypersurfaces in $(\mathbb{C}^*)^{n+1}$ rather than in \mathbb{C}^{n+1} ; we will explain this special case here, and the general situation in Section 1.1. If Z is a hypersurface in $(\mathbb{C}^*)^{n+1}$ we can write its defining equation as $f = 0$, where f is a Laurent polynomial of the form

$$\sum_{m \in \mathbb{Z}^{n+1}} a_m z^m.$$

Here, writing m as (m_1, \dots, m_{n+1}) and the coordinates on $(\mathbb{C}^*)^{n+1}$ as z_1, \dots, z_{n+1} , then z^m denotes the monomial $z_1^{m_1} \dots z_{n+1}^{m_{n+1}}$. The convex hull of the set of m for which the coefficient a_m is nonzero is called the *Newton polytope* of f . By multiplying f by a monomial, we may assume without loss of generality that the Newton polytope contains 0. The significance of this definition is that for a generic choice of coefficients a_m , the topological type of the hypersurface depends only on this polytope. From this point of view, one goal might be to construct a combinatorial skeleton which also depends only on this polytope. Actually, we need a triangulation too. This should not be surprising: a skeleton is not unique, as different Morse functions will produce different skeleta. Purely heuristically, the choice of a triangulation is a combinatorial analogue of the choice of Morse function: different triangulations will produce different skeleta. In fact, we require a “star-regular” triangulation. Section 2 contains the definition of this notion. For now, note that the maximal simplices of such a triangulation are all cone-shaped, and thus the triangulation is determined by a triangulation of the faces which do not meet the origin.

Definition 1.1 Let $\Delta \subseteq \mathbb{R}^{n+1}$ be a lattice polytope with $0 \in \Delta$. Let \mathcal{T}_Δ be a star-regular triangulation of Δ and define \mathcal{T} to be the set of simplices of \mathcal{T}_Δ not meeting 0. Write $\partial\Delta'$ for the support of \mathcal{T} . (Note that $\partial\Delta'$ equals the boundary $\partial\Delta$ if 0 is an interior point. Note also that \mathcal{T} determines \mathcal{T}_Δ , even if $0 \in \partial\Delta$.) Define $S_{\Delta, \mathcal{T}} \subseteq \partial\Delta' \times \text{Hom}(\mathbb{Z}^{n+1}, S^1)$ to be the set of pairs (x, ϕ) satisfying

$$\phi(v) = 1 \quad \text{whenever } v \text{ is a vertex of the smallest simplex } \tau \in \mathcal{T} \text{ containing } x.$$

Put $S := S_{\Delta, \mathcal{T}}$. Then we have the following.

Theorem 1.2 (Main Theorem for $Z \subseteq (\mathbb{C}^*)^n$) *Let Δ and \mathcal{T} be as in Definition 1.1. Let Z be a generic smooth hypersurface whose Newton polytope is Δ . If \mathcal{T} is a star-regular triangulation, then S embeds into Z as a deformation retract.*

We do not know if the hypothesis of a star-regular triangulation can be removed, but note that every lattice polytope admits a star-regular triangulation. The role the triangulation plays in the proof is in the construction of a degeneration of Z . Star-regularity of the triangulation allows the projection $(x, \phi) \mapsto x$ of S to $\partial\Delta$ (or to the support of \mathcal{T} if 0 is on the boundary of Δ) to be identified with the specialization map, under which the skeleton of Z projects to a kind of nonnegative locus of toric components. For more see Section 1.2 below.

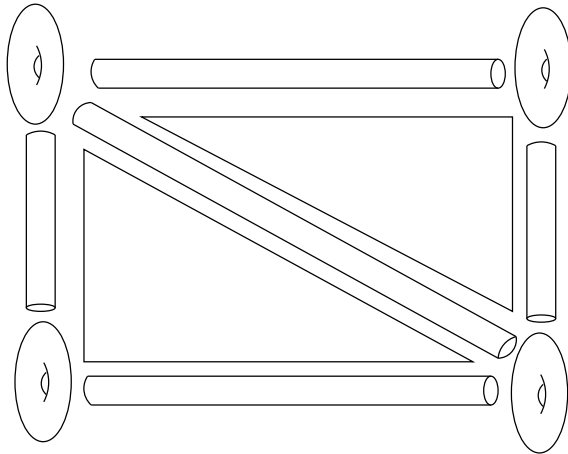

Figure 1: The tetrahedron $\Delta \subseteq \mathbb{R}^3$ with vertices at $(1, 0, 0)$, $(0, 1, 0)$, $(0, 0, 1)$ and $(-1, -1, -1)$ has a unique star triangulation \mathcal{T}_Δ . The figure shows part of $S_{\Delta, \mathcal{T}}$, which by Theorem 1.2 is a skeleton of a surface in $\mathbb{C}^* \times \mathbb{C}^* \times \mathbb{C}^*$ cut out by the quartic equation $ax + by + cz + \frac{d}{xyz} + e = 0$. The tori come from vertices, the tubes come from edges, and the triangles come from faces of the tetrahedron. Each “tube” meeting one of the tori $S^1 \times S^1$ is attached along a different circle, and the resulting figure does not embed in \mathbb{R}^3 . There is a sixth tube and two additional triangles “behind” the diagram, they are to be glued together in the shape of the tetrahedron Δ .

1.1 Main Theorem, general case of Z in an affine toric variety

In Section 5, we prove an extension of Theorem 1.2 to the case where Z is a smooth affine hypersurface in a more general affine toric variety, such as \mathbb{C}^{n+1} , $(\mathbb{C}^*)^k \times \mathbb{C}^l$,

or even singular spaces such as $\mathbb{C}^2/(\mathbb{Z}/2)$. In these cases, we define the skeleton as a quotient of the construction of [Definition 1.1](#).

Definition 1.3 Let Δ , \mathcal{T} and $S_{\Delta, \mathcal{T}}$ be as in [Definition 1.1](#), so in particular $0 \in \Delta$. Let $K = \mathbb{R}_{\geq 0} \Delta$ be the rational polyhedral cone generated by Δ . Define $S_{\Delta, \mathcal{T}, K}$ to be the quotient of $S_{\Delta, \mathcal{T}}$ by the equivalence relation

$$(x, \phi) \sim (x', \phi') \quad \text{if } x = x' \text{ and } \phi|_{K_x \cap M} = \phi'|_{K_x \cap M},$$

where K_x denotes the smallest face of K containing x .

The cone K determines an affine toric variety $\text{Spec}(\mathbb{C}[K \cap M])$. If this is smooth or has at most one isolated singularity, and if Z is a smooth hypersurface in $\text{Spec}(\mathbb{C}[K \cap M])$ with Newton polytope Δ and generic coefficients, then Z deformation retracts onto a subspace homeomorphic to $S_{\Delta, \mathcal{T}, K}$. (The hypothesis that $K = \mathbb{R}_{\geq 0} \Delta$ can be weakened; see [Assumption 5.3\(3\)](#).)

To illustrate, let us describe two skeleta of the subvariety of \mathbb{C}^3 cut out by a generic quadric; in fact, $x^2 + y^2 + z^2 = 1$ is sufficiently generic and we should expect Z and its skeleton to be homotopy equivalent to a 2–sphere. In this case Δ is the convex hull of $\{(0, 0, 0), (2, 0, 0), (0, 2, 0), (0, 0, 2)\}$ and $K = \mathbb{R}_{\geq 0}^3$. The part $\partial\Delta'$ of $\partial\Delta$ to be triangulated is the face $\{(2, 0, 0), (0, 2, 0), (0, 0, 2)\}$, and we can describe $S_{\Delta, \mathcal{T}, K}$ in terms of the projection map to $\partial\Delta'$. We shall consider two triangulations of $\partial\Delta'$, leading to two nonhomeomorphic but homotopy-equivalent skeleta that we call *octahedron* and *Klein bottle sandwich*.

Octahedron If we give $\partial\Delta'$ its canonical triangulation, ie $\partial\Delta'$ itself is the only top-dimensional simplex, then the skeleton $S_{\Delta, \mathcal{T}, K}$ is homeomorphic to S^2 . In fact it is combinatorially an octahedron:

$$\{(x_1, x_2, x_3) \in \mathbb{R}^3 \mid |x_1| + |x_2| + |x_3| = 2\}$$

The map $S_{\Delta, \mathcal{T}, K} \rightarrow \partial\Delta'$ is finite and homeomorphic to the eight-to-one map, branched over the boundary of $\partial\Delta'$, carrying a point (x, y, z) to $(|x|, |y|, |z|)$. The factor of 8 in the branched cover arises from the nonunimodularity of the (single) maximal simplex of the triangulation. More precisely, the size of the preimage of a point $x \in \partial\Delta'$ is given by the index of the sublattice in $M \cap \mathbb{R} \tau_x$ generated by the vertices of τ_x with τ_x being the smallest simplex in $\partial\Delta'$ containing x . One finds that this is 2 for the vertices, 4 for edges and 8 on the maximal simplex and the gluing of these preimages precisely gives the octahedron.

Klein bottle sandwich When we triangulate $\partial\Delta'$ as in the following diagram, the skeleton $S_{\Delta, \mathcal{T}, K}$ is homotopy equivalent to S^2 , but through a different construction.

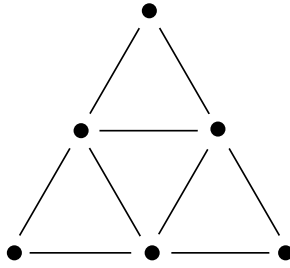

We first note that just as $\partial\Delta'$ retracts to the central triangle, so does $S_{\Delta,\mathcal{T},\mathcal{K}}$ retract to the preimage of the central triangle, so we focus our attention there. Call T the central triangle and S its preimage, with $\pi: S \rightarrow T$ the projection. The fibers of π over the boundary of T are circles, so the preimage of the boundary of T is topologically an S^1 fibration over S^1 . In fact, it is a Klein bottle. The map π is two to one on the interior of T , and the two triangles of the preimage have the same effect, up to homotopy, as contracting two sections of the Klein bottle fibration over S^1 . At this point, recall that the Klein bottle can be constructed from S^2 by blowing up the north and south poles, and that it fibers over the S^1 worth of meridians. The two exceptional S^1 are sections, and they get contracted by the blowdown to S^2 . As the two triangles above perform the contracting blowdown, we conclude that $S_{\Delta,\mathcal{T},\mathcal{K}}$ is homotopy equivalent to S^2 .

1.2 Log geometry and the proof

The technique of the proof is to use the triangulation to construct a degeneration of the ambient $(\mathbb{C}^*)^{n+1}$, and with it the hypersurface. Each component of the degeneration is an affine space \mathbb{C}^{n+1} , or the quotient of an affine space by a finite commutative group, along which the hypersurface has a simple description: it is an affine Fermat hypersurface, and thus a finite branched cover over affine space \mathbb{C}^n ; see also the discussion of Mikhalkin’s work in Section 1.3. So the degenerated hypersurface is well understood.

Example 1.4 Consider the space $Z = \{-1 + x + y + x^{-1}y^{-1} = 0\}$ inside $\mathbb{C}^* \times \mathbb{C}^*$, which is topologically a two-torus with three points removed. The Newton polytope $\Delta = \text{conv}(\{(1, 0), (0, 1), (-1, -1)\}) \subseteq \mathbb{R}^2$ has a unique star-regular triangulation corresponding to the unique lattice triangulation of its boundary. To understand the associated degeneration, first identify $\mathbb{C}^* \times \mathbb{C}^*$ with the locus $\{abc = 1\} \subseteq \mathbb{C}^3$ and describe Z by the equation $-1 + a + b + c = 0$. Next we can identify this geometry with the locus $t = 1$ inside the family $\{abc = t^3\} \subseteq \mathbb{C}^4$. At $t = 0$, we have for the ambient space $\mathbb{C}^2_{\{a=0\}} \cup \mathbb{C}^2_{\{b=0\}} \cup \mathbb{C}^2_{\{c=0\}}$, with the hypersurface described by $\{b + c = 1\} \cup \{c + a = 1\} \cup \{a + b = 1\}$, ie a union of affine lines.

The degenerated hypersurface deformation retracts onto a simple locus which can be triangulated explicitly (this triangulation occurs for the first time in Deligne [10]). In each component, the top-dimensional simplices of this triangulation are the *nonnegative loci* of the components, together with their translates by a finite subgroup of $(\mathbb{C}^*)^{n+1}$. For instance in Example 1.4, the complex line $\{a + b = 1\} \subseteq \mathbb{C}_{c=0}^2$ retracts to the real interval $\{a + b = 1, a \geq 0, b \geq 0\}$. What remains is to account for the topological difference between the degenerated hypersurface and the general one. To the reader familiar with the theory of vanishing cycles (which measure the cohomological difference between the degenerate hypersurface and the general one), this will suggest that we take for a skeleton of Z the preimage under a “specialization” map of the skeleton for Z_0 . Log geometry gives a way of making this precise.

The toric setting of log geometry is particularly simple. A toric variety comes with a standard log structure which can be pulled back to a toric stratum, enabling the stratum to “remember” how it is embedded in the ambient space. In short, the compact torus fixing the defining equations of a stratum of the degeneration serves as the exceptional torus in a real, oriented blowup from which one can extract the nearby fiber of the degenerate hypersurface.

Example 1.5 To illustrate this point, consider first the local geometry of the degeneration near a singular point of Example 1.4, ie $\{uv = \epsilon^3\} \subseteq \mathbb{C}^2$. The two-torus $S^1 \times S^1 \subseteq \mathbb{C}^* \times \mathbb{C}^*$ acts on \mathbb{C}^2 and the “antidiagonal” circle fixes the defining equation for all ϵ . As ϵ goes to zero, this antidiagonal circle becomes homotopically trivial since it retracts to the fixed point $(0, 0)$ in $U = \{uv = 0\}$. We want to “keep” this circle by remembering the way we took the limit. Let $\rho: V \rightarrow U$ be a retraction map from some fiber $\epsilon \neq 0$ to U . To find the skeleton, we take the nonnegative real locus $\bar{S} = \{(u, v) \in \mathbb{R}_{\geq 0}^2 \mid uv = 0\}$ in U and find the skeleton S as the inverse image of \bar{S} under ρ which has the effect of attaching a circle at the point $(0, 0)$ in \bar{S} . Doing this globally in Example 1.4 yields a skeleton S that is the boundary of a triangle (by gluing the three \bar{S} ’s) with a circle attached at each of the three vertices.

1.3 Related work

A skeleton for Fermat hypersurfaces was described by Deligne in [10, pages 88–90], and this skeleton is visible in our own in a manner described in Remark 3.21. Abouzaid [2] presents some examples of skeleta which are homeomorphic to the ones we define, though via different means. Our “skeleta” are different than the “skeleta” that appear in nonarchimedean geometry (see Berkovich [6] and Kontsevich and Soibelman [22]), but $\partial\Delta'$ plays a similar role in both constructions. It would be interesting to study this resemblance further.

Hypersurfaces in algebraic tori have been studied by Danilov and Khovanskiĭ [9] and Batyrev [5]. Danilov and Khovanskiĭ computed mixed Hodge numbers, while Batyrev studied the variation of mixed Hodge structures. Log geometry has been extensively employed by Gross and Siebert [17] in their seminal work studying the degenerations appearing in mirror symmetry. Their strategy is crucial to our work, even though we take a somewhat different track by working in a noncompact setting for hypersurfaces that are not necessarily Calabi–Yau. The noncompactness allows us to deal with log-smooth log structures. Mirror symmetry for general hypersurfaces was recently studied by Gross, Katzarkov and the first author in [16] (projective case) and Abouzaid, Auroux and Katzarkov in [3] (affine case) using polyhedral decompositions of the Newton polytope. This relates to the Gross–Siebert program by embedding the hypersurface in codimension two in the special fiber of a degenerating Calabi–Yau family. In this family, the hypersurface coincides with the log singular locus; see the first author [27] for the simplicial case.

In the symplectic-topological setting, Mikhalkin [25] constructed a degeneration of a projective algebraic hypersurface using a triangulation of its Newton polytope to provide a higher-dimensional “pair of pants” decomposition. He further identified a stratified torus fibration over the spine of the corresponding amoeba. This viewpoint was first applied to homological mirror symmetry (HMS) by Abouzaid [1]. Mikhalkin’s construction and perspective inform the current work greatly, even though our route from HMS is a bit “top down”. We describe it here.

When Δ is reflexive, Z can be seen as the “large volume limit” of a family of Calabi–Yau hypersurfaces in the toric variety \mathbb{P}_Δ defined by Δ . The dual polytope Δ^\vee corresponds to the toric variety \mathbb{P}_{Δ^\vee} containing the mirror family. The mirror “large complex structure limit” Z^\vee is the union of reduced toric divisors of \mathbb{P}_{Δ^\vee} . In [12], Fang, Liu and the third and fourth authors found a relation between coherent sheaves on a toric variety, such as \mathbb{P}_{Δ^\vee} , and a subcategory of constructible sheaves on a real torus. The subcategory is defined by a conical Lagrangian Λ in the cotangent bundle of the torus. As discussed by the third and fourth authors in [29], specializing to Z^\vee , the complement of the open orbit of \mathbb{P}_Δ , can be achieved by excising the zero section from Λ . The resulting conical Lagrangian is homotopy equivalent to the Legendrian Λ^∞ at contact infinity of the cotangent bundle. We can now explain how this relates to skeleta. First, when Δ is reflexive and simplicial and we choose \mathcal{T} to be the canonical triangulation of its boundary, then S is homeomorphic to Λ^∞ . In [29] it is shown that Λ^∞ supports a Kashiwara–Schapira sheaf of dg categories, and this is equivalent to the “constructible plumbing model” of the second, third and fourth authors [28]. Following [28], this sheaf should be equivalent to perfect complexes on Z^\vee and it is conjectured in [29] that under homological mirror symmetry it is also equivalent to the sheaf of Fukaya

categories, conjectured to exist by Kontsevich, supported on the skeleton of Z . In particular, S should be the skeleton of Z itself, and in the simplicial reflexive case this was conjectured in [29].

1.4 Notation and conventions

1.4.1 Hypersurfaces in an algebraic torus Each $(m_0, \dots, m_n) \in \mathbb{Z}^{n+1}$ determines a monomial function $(\mathbb{C}^*)^{n+1} \rightarrow \mathbb{C}$ which we denote by $z^m = \prod_{i=0}^{n+1} z_i^{m_i}$. If $f: (\mathbb{C}^*)^{n+1} \rightarrow \mathbb{C}$ is a Laurent polynomial we let $V(f) = \{z \mid f(z) = 0\}$ denote its zero locus. The *Newton polytope* of f is the convex hull of the set of $m \in \mathbb{Z}^{n+1}$ whose coefficient in f is nonzero. If the coefficients are chosen generically, then the diffeomorphism type of $V(f)$ depends only on the Newton polytope of f . In fact it suffices that the extreme coefficients (ie the coefficients corresponding to the vertices of the Newton polytope) are chosen generically. More precisely, we have the following.

Proposition 1.6 (Gelfand, Kapranov and Zelevinsky [15, Chapter 10, Corollary 1.7]) *Let $A \subseteq \mathbb{Z}^{n+1}$ be a finite set whose affine span is all of \mathbb{Z}^{n+1} , and let f_A be a Laurent polynomial of the form*

$$f(z) = \sum_{m \in A} a_m z^m.$$

There is a Zariski dense open subset $U_A \subseteq \mathbb{C}^{|A|}$ such that, when the $(a_m)_{m \in A}$ are chosen from U_A , the variety $V(f_A)$ is smooth and its diffeomorphism type depends only on the convex hull of A .

Remark 1.7 The precise condition that we mean by “generic” in [Theorem 1.2](#) is as follows. If \bar{Z} denotes the closure of Z in the projective toric variety \mathbb{P}_Δ associated to Δ then we require $\bar{Z} \cap O$ to be either empty or smooth and reduced for each torus orbit $O \subseteq \mathbb{P}_\Delta$. If this holds, \bar{Z} is called Δ -regular, a notion coined by Batyrev and Dwork; see [5, Definition 3.3]. Note that for each cell $\tau \in \mathcal{T}$, we may consider the weighted projective space \mathbb{P}_τ associated to τ and have a hypersurface $\bar{Z}_\tau \subseteq \mathbb{P}_\tau$ given by the polynomial $f_\tau = \sum_{m \in \tau} a_m z^m$. Now, we may state the precise definition of generic used in [Theorem 1.2](#): we call Z generic if \bar{Z} is Δ -regular and for each $\tau \in \mathcal{T}$, \bar{Z}_τ is τ -regular. The set of generic hypersurfaces forms a Zariski open subset of all hypersurfaces justifying the notion *generic*.

1.4.2 Polytopes and triangulations An intersection of finitely many affine half-spaces in a finite-dimensional vector space is called *polyhedron*. If it is compact, it is called *polytope*. A polytope is the convex hull of its vertices. Given a subset A of a vector space, we denote its convex hull by $\text{conv}(A)$. Throughout, we let M

denote a free abelian group isomorphic to \mathbb{Z}^{n+1} and set $M_{\mathbb{R}} = M \otimes_{\mathbb{Z}} \mathbb{R} \cong \mathbb{R}^{n+1}$. A polytope $\Delta \subseteq M_{\mathbb{R}}$ is called a *lattice polytope* if its vertices are in M . We use the symbol \subseteq for the face relation, eg, $\tau \subseteq \Delta$ means that τ is a face of Δ . The relative interior of a polytope τ will be denoted τ° . Let $\partial\Delta$ denote the boundary of Δ . A *lattice triangulation* \mathcal{T}_Δ of a polytope Δ is a triangulation by lattice simplices. Such a triangulation is called *star-regular* if there is a convex, piecewise linear function $h: \Delta \rightarrow \mathbb{R}$ such that the nonextendable closed domains where h is affine linear coincide with the maximal simplices in \mathcal{T}_Δ . Note that star-regularity is different from usual regularity where one would relax the linearity condition to affine-linearity. In a star-regular triangulation, all maximal simplices contain the origin, which wouldn't be true for a general regular triangulation. We write $\mathcal{T}_\Delta^{[0]}$ for the set of vertices of \mathcal{T}_Δ , and if τ is a simplex of \mathcal{T}_Δ we write $\tau^{[0]}$ for the vertices of τ .

1.4.3 Monoids and affine toric varieties We denote by $\text{Spec } R$ the spectrum of a commutative ring R , where R is a Noetherian commutative algebra over \mathbb{C} . We will often abuse notation by using the same symbol $\text{Spec } R$ for the associated complex analytic space and \mathcal{O} for \mathcal{O}^{an} . Given $f_1, \dots, f_r \in R$, we write $V(f_1, \dots, f_r)$ for the subvariety of $\text{Spec } R$ defined by the equations $f_1 = \dots = f_r = 0$.

A *monoid* is a set with an associative binary operation that has a unit and a two-sided identity. For us, all monoids will be commutative. Given a monoid M with an action on a set V , we write MT for the orbit of a subset $T \subseteq V$. We often use this when V is an \mathbb{R} -vector space, T some subset and $M = \mathbb{R}_{\geq 0}$ the nonnegative reals. Further notation for monoids is discussed in [Section 4.1](#).

By a *cone* $\sigma \subseteq M_{\mathbb{R}}$ we shall always mean a rational polyhedral cone, ie a set of the form

$$\left\{ \sum_{i \in I} \lambda_i v_i \mid \lambda_i \in \mathbb{R}_{\geq 0} \right\},$$

where $\{v_i\}_{i \in I}$ is a finite subset of lattice vectors in $M_{\mathbb{R}}$. A cone is called *strictly convex* if it contains no nonzero linear subspace of $M_{\mathbb{R}}$. Gordon's Lemma (see Fulton [14, page 12]) states that the monoid $M \cap \sigma$ is finitely generated. The monoid ring $\mathbb{C}[M \cap \sigma]$ is then Noetherian. For $m \in M \cap \sigma$ we write z^m for the corresponding basis element of $\mathbb{C}[M \cap \sigma]$; it can be regarded as a *regular monomial* function $\text{Spec } \mathbb{C}[M \cap \sigma] \rightarrow \mathbb{C}$.

We have the following standard device for describing points on an affine toric variety. If x is a point of $\text{Spec } \mathbb{C}[M \cap \sigma]$, write $\text{ev}_x: M \cap \sigma \rightarrow \mathbb{C}$ for the map

$$\text{ev}_x(m) = z^m$$

evaluated at x . Each ev_x is a homomorphism of monoids from $M \cap \sigma$ to (\mathbb{C}, \times) . The universal property of the monoid ring gives the following.

Proposition 1.8 *Let σ be a rational polyhedral cone in $M_{\mathbb{R}}$. Then $x \mapsto \text{ev}_x$ is a one-to-one correspondence between the complex points of $\text{Spec } \mathbb{C}[M \cap \sigma]$ and the monoid homomorphisms $M \cap \sigma \rightarrow \mathbb{C}$.*

Acknowledgements We thank Gabriel Kerr for his help with the case of nonreflexive polytopes. We thank Nir Avni, Johan de Jong, Grigory Mikhalkin, Sam Payne and Bernd Siebert for helpful discussions. The work of the first author is supported by DFG-SFB-TR-45 and the Carl Zeiss Foundation. The work of the third author is supported by NSF-DMS-1206520. The work of the fourth author is supported by NSF-DMS-1104779 and by a Simons Foundation Fellowship.

2 Degenerations of hypersurfaces

We fix a lattice polytope $\Delta \subseteq M_{\mathbb{R}}$ with $0 \in \Delta$. Let $K \subseteq M_{\mathbb{R}}$ be a convex subset. A continuous function $h: K \rightarrow \mathbb{R}$ is called *convex* if for each $m, m' \in K$ and we have

$$\frac{h(m) + h(m')}{2} \geq h\left(\frac{m + m'}{2}\right).$$

We fix a lattice triangulation \mathcal{T}_{Δ} of Δ with the following property: $0 \in \mathcal{T}_{\Delta}^{[0]}$ and there exists a convex piecewise linear function $h: \mathbb{R}_{\geq 0}\Delta \rightarrow \mathbb{R}$ taking nonnegative integral values on M such that the maximal dimensional simplices in \mathcal{T}_{Δ} coincide with the nonextendable closed domains of linearity of $h|_{\Delta}$. We also choose such a function, h . Triangulations with this property are often called *regular* or *coherent*. Every lattice polytope containing the origin supports a regular lattice triangulation. Since h is linear on the $(n + 1)$ -simplices of \mathcal{T}_{Δ} , this triangulation is “star-shaped with center 0” in the sense that each simplex in \mathcal{T}_{Δ} is contained in $\partial\Delta$ or contains the origin 0. We define the triangulation \mathcal{T} by

$$\mathcal{T} = \{\tau \in \mathcal{T}_{\Delta} \mid \tau \subseteq \partial\Delta, 0 \notin \tau\},$$

ie, the set of simplices of Δ not containing the origin. We denote the union of all $\tau \in \mathcal{T}$ by $|\mathcal{T}|$, and sometimes by $\partial\Delta'$. Since \mathcal{T} induces \mathcal{T}_{Δ} , we call \mathcal{T} regular if the induced \mathcal{T}_{Δ} is regular.

We fix a Laurent polynomial $f \in \mathbb{C}[M]$ of the form

$$(2-1) \quad f = a_0 + \sum_{m \in \mathcal{T}^{[0]}} a_m z^m.$$

We suppose that all coefficients are real, that $a_0 < 0$, that $a_m > 0$ for $m \in \mathcal{T}^{[0]}$, and that they are chosen generically with this property. We write $V(f) \subseteq \text{Spec } \mathbb{C}[M]$ for the hypersurface in the algebraic torus defined by $f = 0$.

Remark 2.1 Since the positivity conditions on the a_m are Zariski dense, it follows by Proposition 1.6 that $V(f)$ is smooth and diffeomorphic to any generic hypersurface whose Newton polytope is Δ .

Using the piecewise linear function h , we can give a toric degeneration of $(\mathbb{C}^*)^{n+1}$ and an induced degeneration of $V(f)$ in the style of Mumford. We construct this degeneration in Sections 2.1 and 2.2.

Remark 2.2 In case the origin is on the boundary of Δ , it is natural to embed $V(f)$ into the following partial compactification of $(\mathbb{C}^*)^{n+1}$. The polytope Δ generates a cone $\mathbb{R}_{\geq 0}\Delta \subseteq M_{\mathbb{R}}$. The cone is not usually strictly convex, eg if $0 \in \Delta^\circ$ then this cone is all of $M_{\mathbb{R}}$. In any case, f is always a linear combination of monomials in $\mathbb{R}_{\geq 0}\Delta \cap M$ and defines a hypersurface in $\text{Spec } \mathbb{C}[M \cap \mathbb{R}_{\geq 0}\Delta]$ which we denote by $\bar{V}(f)$. If $0 \in \Delta^\circ$, $\bar{V}(f) = V(f)$.

2.1 Degeneration of the ambient space

The total space of the degeneration will be an affine toric variety Y closely related to the affine cone over the projective toric variety whose moment polytope is Δ . More precisely, it is an affine subset of the affine cone over a blowup of this toric variety. The construction makes use of the *overgraph cone* in $M_{\mathbb{R}} \oplus \mathbb{R}$, coming from the piecewise-linear function h .

2.1.1 The overgraph cone Let $\Sigma_{\mathcal{T}}$ be the fan in $M_{\mathbb{R}}$ whose nonzero cones are the cones over the simplices in \mathcal{T} , ie

$$\Sigma_{\mathcal{T}} = \{\mathbb{R}_{\geq 0}\tau \mid \tau \in \mathcal{T}\}.$$

When 0 is an interior lattice point, $\Sigma_{\mathcal{T}}$ is a complete fan. In general its support is the cone $\mathbb{R}_{\geq 0}\Delta$.

Since \mathcal{T} is regular, $\Sigma_{\mathcal{T}}$ is projected from part of the boundary of a rational polyhedral cone in $M_{\mathbb{R}} \oplus \mathbb{R}$. We fix such a cone and call it the *overgraph cone*. Let us define it more precisely. Set $\tilde{M} = M \oplus \mathbb{Z}$ and $\tilde{M}_{\mathbb{R}} = \tilde{M} \otimes_{\mathbb{Z}} \mathbb{R}$. The overgraph cone of h is defined to be

$$\Gamma_{\geq h} = \{(m, r) \in \tilde{M}_{\mathbb{R}} \mid m \in \mathbb{R}_{\geq 0}\Delta, r \geq h(m)\}.$$

Each cone in $\Sigma_{\mathcal{T}}$ is isomorphic to a proper face of $\Gamma_{\geq h}$ under the projection $\widetilde{M}_{\mathbb{R}} \rightarrow M_{\mathbb{R}}$. The inverse isomorphism is given by $m \mapsto (m, h(m))$. Since h takes integral values on M , the faces of $\Gamma_{\geq h}$ that appear in this way form a rational polyhedral fan in \widetilde{M} . We record this observation in the following lemma.

Lemma 2.3 *Let $\mathbb{R}_{\geq 0}\tau$ be a cone in $\Sigma_{\mathcal{T}}$ and let $\Gamma_{\geq h, \tau} \subseteq \Gamma_{\geq h}$ be the face*

$$\Gamma_{\geq h, \tau} = \{(m, h(m)) \in \Gamma_{\geq h} \mid m \in \mathbb{R}_{\geq 0}\tau\}.$$

Then the projection $\Gamma_{\geq h, \tau} \rightarrow \mathbb{R}_{\geq 0}\tau$ is an isomorphism of cones inducing an isomorphism of monoids $\Gamma_{\geq h, \tau} \cap \widetilde{M} \rightarrow \mathbb{R}_{\geq 0}\tau \cap M$.

2.1.2 Degeneration The overgraph cone determines an affine toric variety that we denote by Y , ie

$$Y = \text{Spec } \mathbb{C}[\Gamma_{\geq h} \cap \widetilde{M}].$$

Define $\pi: Y \rightarrow \mathbb{A}^1$ to be the map given by the regular monomial function $t = z^{(0,1)}$ on Y . Let $Y_0 \subseteq Y$ denote the fiber $\pi^{-1}(0)$. Since t is a monomial, Y_0 is torus invariant in Y , but in general has many irreducible components. Let us call the components of $\pi^{-1}(0)$ the *vertical divisors* of the map π and then call the remaining toric prime divisors *horizontal divisors*.

Remark 2.4 Since Y is an affine toric variety, we can identify the points of Y (by Proposition 1.8) with the space of monoid homomorphisms $(\widetilde{M} \cap \Gamma_{\geq h}, +) \rightarrow (\mathbb{C}, \times)$. In this description, Y_0 is the subset of monoid homomorphisms $\phi: \widetilde{M} \cap \Gamma_{\geq h} \rightarrow \mathbb{C}$ carrying $(0, 1)$ to 0.

Proposition 2.5 *The map $\pi: Y \rightarrow \mathbb{A}^1$ has the following properties.*

- (1) *We have $\pi^{-1}(\mathbb{C}^*) = \text{Spec } \mathbb{C}[(\mathbb{R}_{\geq 0}\Delta) \cap M] \times \mathbb{C}^*$ and the restriction of π to $\pi^{-1}(\mathbb{C}^*)$ is the projection onto the second factor.*
- (2) *The subscheme structure on $Y_0 = \pi^{-1}(0)$ is reduced.*
- (3) *We have π is a toric degeneration of $\text{Spec } \mathbb{C}[(\mathbb{R}_{\geq 0}\Delta) \cap M]$. The restriction of π to the complement of the union of horizontal divisors is a degeneration of $\text{Spec } \mathbb{C}[M] \cong (\mathbb{C}^*)^{n+1}$.*

Proof Localizing to $\pi^{-1}(\mathbb{C}^*)$ means adjoining t^{-1} to the ring $\mathbb{C}[\Gamma_{\geq h} \cap \widetilde{M}]$, which yields $\mathbb{C}[(\mathbb{R}_{\geq 0}\Delta) + \mathbb{R}(0, 1) \cap \widetilde{M}] = \mathbb{C}[(\mathbb{R}_{\geq 0}\Delta) \cap M] \otimes_{\mathbb{C}} \mathbb{C}[\mathbb{Z}]$. This gives the first statement in (3) as well as (1).

To prove (2), note that since h takes integral values on M , any element $m \in \Gamma_{\geq h} \cap \widetilde{M}$ can uniquely be written as

$$m' + k(0, 1),$$

with $k \in \mathbb{Z}_{\geq 0}$ and m' in $\Gamma_{\geq h, \tau} \cap \widetilde{M}$ for some $\tau \in \mathcal{T}$. We need to show that the ideal $J = (z^{(0,1)})$ of $A := \mathbb{C}[\Gamma_{\geq h} \cap \widetilde{M}]$ is radical. Let $f \in A$ be given such that $f^l \in J$. We need to show that $f \in J$. We have $\text{Newton}(f^l) = l \cdot \text{Newton}(f)$, where $\text{Newton}(g)$ denotes the Newton polytope of g . Since by assumption all lattice points in $\text{Newton}(f^l)$ have $k > 0$ under the above decomposition, this also follows for those in $\text{Newton}(f)$ and thus $f \in J$.

The second statement in (3) is best seen in the fan picture. If Σ is the normal fan of $\Gamma_{\geq h}$, removing the horizontal divisors amounts to restricting to the subfan $\Sigma' \subseteq \Sigma$ of cones that have no rays contained in $(0, 1)^\perp$. The map π is given by mapping Σ' to the fan $\{\{0\}, \mathbb{R}_{\geq 0}\}$ and $\{0\} \in \Sigma'$ is the only cone that maps to $\{0\}$, so the general fiber is indeed an algebraic torus. \square

Let us describe the vertical and the horizontal divisors in more detail.

Proposition 2.6 *Let Y and π be as above and for each $\tau \in \mathcal{T}$ let $\Gamma_{\geq h, \tau}$ be as in Lemma 2.3.*

- (1) *The assignment $\tau \mapsto \text{Spec } \mathbb{C}[\Gamma_{\geq h, \tau} \cap \widetilde{M}]$ is a bijection between the vertical divisors of π and the n -dimensional simplices of \mathcal{T} .*
- (2) *The assignment*

$$\tau \mapsto \text{Spec } \mathbb{C}[(\mathbb{R}_{\geq 0}\{(m, h(m)) \mid m \in \tau\} + \mathbb{R}_{\geq 0}(0, 1)) \cap \widetilde{M}]$$

is a bijection between the horizontal divisors of π and the n -dimensional simplices τ of \mathcal{T}_Δ with $0 \in \tau$ and $\tau \subseteq \partial\Delta$.

Proof The toric prime divisors in Y correspond to the codimension one faces of $\Gamma_{\geq h}$. Such a face corresponds to a vertical divisor if and only if it contains $(0, 1)$. This implies (1) and (2). \square

Example 2.7 For a simple illustrative example, take $\Delta = \text{conv}(\{(0, 0), (2, 0), (0, 2)\})$, with lattice points named as follows:

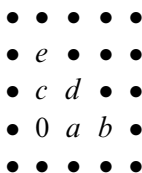

Then $\partial\Delta'$ is the line segment between b and e , and let us take \mathcal{T} to be the fine triangulation with maximal simplices \overline{bd} and \overline{de} . Then $\Sigma_{\mathcal{T}}$ is supported in the first quadrant, and its maximal cones are generated by $\{b, d\}$ and $\{d, e\}$. Let h be the piecewise linear function supported on $\Sigma_{\mathcal{T}}$ with

$$h(a) = 1, \quad h(c) = 1, \quad h(d) = 1.$$

Then, we have that the ring $\mathbb{C}[\Gamma_{\geq h} \cap \widetilde{M}]$ of regular functions on Y can be identified with $\mathbb{C}[a, c, d, t]/(ac - dt)$. (We identify a with $z^a t^{h(a)}$ and so on.) For $\lambda \neq 0$, the fiber $\pi^{-1}(\lambda)$ can be identified with \mathbb{C}^2 via $(a, c) \leftrightarrow (a, c, ac/\lambda, \lambda)$, as it must from Proposition 2.5(1) since $\text{Spec } \mathbb{C}[(\mathbb{R}_{\geq 0}\Delta) \cap M] \cong \mathbb{C}^2$.

Setting $t = 0$ gives Y_0 as $\mathbb{C}[a, c, d]/ac$ which reveals the vertical divisors as $V(c, t) \cong \mathbb{C}^2 = \{(a, d)\}$ and $V(a, t) \cong \mathbb{C}^2 = \{(c, d)\}$. The horizontal divisors are $V(a, d)$ and $V(c, d)$, which can also be identified with \mathbb{C}^2 . In Example 2.14 we shall return to this example to consider hypersurface degenerations when we have a polynomial f with $\text{Newton}(f) = \Delta$.

Remark 2.8 In these examples we have used coordinates on Y indexed by lattice points in Δ . This is always possible for $n \leq 1$, but for larger n the coordinate ring of Y can require many more generators.

2.1.3 Orbit closures in Y_0 For each $\tau \in \mathcal{T}$ let $Y_{0,\tau}$ be the $(\dim(\tau) + 1)$ -dimensional affine toric variety

$$Y_{0,\tau} = \text{Spec}(\mathbb{C}[\widetilde{M} \cap \Gamma_{\geq h,\tau}]),$$

where $\Gamma_{\geq h,\tau}$ is defined in Lemma 2.3. Since $\Gamma_{\geq h,\tau}$ is a face of $\Gamma_{\geq h}$, $Y_{0,\tau}$ is a torus orbit closure in Y . Each vertical divisor of t is of the form $Y_{0,\tau}$, where τ is an n -dimensional simplex of \mathcal{T} by Proposition 2.6.

Restricting regular functions from Y to $Y_{0,\tau}$ induces the ring quotient map

$$\mathbb{C}[\Gamma_{\geq h} \cap \widetilde{M}] \rightarrow \mathbb{C}[\Gamma_{\geq h,\tau} \cap \widetilde{M}]$$

whose kernel is the ideal generated by monomials $z^{(m,r)}$ with $(m, r) \notin \Gamma_{\geq h,\tau}$. By Lemma 2.3, we may identify $\mathbb{C}[\Gamma_{\geq h,\tau} \cap \widetilde{M}]$ with $\mathbb{C}[\mathbb{R}_{\geq 0}\tau \cap M]$.

2.1.4 Projection onto $\mathbb{P}^{\dim(\tau)}$ The action of $\text{Hom}(M, \mathbb{C}^*)$ on $Y_{0,\tau}$ factors through an action of the quotient torus $\text{Hom}(\mathbb{R}\tau \cap M, \mathbb{C}^*)$. We now define a finite subgroup $D_{\tau} \subseteq \text{Hom}(\mathbb{R}\tau \cap M, \mathbb{C}^*)$ which will play an important role for us.

Definition 2.9 Let D_τ be the finite commutative group

$$D_\tau = \text{Hom}((M \cap \mathbb{R}\tau)/\mathbb{Z}\tau^{[0]}, \mathbb{C}^*).$$

We regard D_τ as a subgroup of $\text{Hom}(M \cap \mathbb{R}\tau, \mathbb{C}^*)$, and let it act on the coordinate ring of $Y_{0,\tau} = \text{Spec } \mathbb{C}[M \cap \mathbb{R}_{\geq 0}\tau]$ by

$$d.z^m = d(m) z^m.$$

Proposition 2.10 *The invariant subring*

$$\mathbb{C}[M \cap \mathbb{R}_{\geq 0}\tau]^{D_\tau} \subseteq \mathbb{C}[M \cap \mathbb{R}_{\geq 0}\tau]$$

is the monoid ring $\mathbb{C}[\mathbb{Z}_{\geq 0}\tau^{[0]}]$. In other words, it is a polynomial ring whose $\dim(\tau) + 1$ variables are parameterized by the vertices $\tau^{[0]}$ of τ .

Proof The monomials z^m for $M \cap \mathbb{R}_{\geq 0}\tau$ form a basis of eigenvectors for the D_τ -action on $\mathbb{C}[M \cap \mathbb{R}_{\geq 0}\tau]$. The invariants are therefore generated by those monomials z^m for which $d(m) = 1$ for all $d \in D_\tau$. Each vertex of τ has this property, and thus

$$\mathbb{Z}_{\geq 0}\tau^{[0]} \subseteq \{m \in \mathbb{R}_{\geq 0}\tau \cap M \mid d(m) = 1 \text{ for all } d \in D_\tau\}.$$

Let us show the containment is an equality, ie that for each $m \in M \cap \mathbb{R}_{\geq 0}\tau$, if the monomial z^m is D_τ -invariant then m is a $\mathbb{Z}_{\geq 0}$ -linear combination of the vertices of τ . This follows from the fact that $\tau^{[0]}$ is a basis for the vector space $\mathbb{R}\tau$, and that each element of $M \cap \mathbb{R}_{\geq 0}\tau$ can be written in this basis with coefficients in $\mathbb{Q}_{\geq 0}$. Indeed, let $v_0, v_1, \dots, v_{\dim(\tau)}$ be the vertices of τ and for $i = 0, \dots, \dim(\tau)$ define d_i by $d_i(v_j) = \delta_{i,j}$. Suppose that z^m is a D_τ -invariant monomial. Then since $m = \sum a_i v_i$ where each a_i is in $\mathbb{Q}_{\geq 0}$, we have $d_j(m) = e^{2\pi i a_j} = 1$ for all j , ie $a_j \in \mathbb{Z}_{\geq 0}$. \square

Proposition 2.11 *The fiber of the D_τ -quotient map*

$$Y_{0,\tau} \rightarrow \mathbb{C}^{\dim(\tau)+1}$$

above $0 \in \mathbb{C}^{\dim(\tau)+1}$ is a single point.

Note there is a mild abuse of notation here: the coordinates of $\mathbb{C}^{\dim(\tau)+1}$ are not indexed by the integers $1, \dots, n + 1$ but the vertices of τ .

Proof We use the description of [Proposition 1.8](#). The origin in $\mathbb{C}^{\dim(\tau)+1}$ corresponds to the monoid homomorphism $\mathbb{Z}_{\geq 0}\tau^{[0]} \rightarrow \mathbb{C}$ that carries each vertex of τ (and in fact each nonzero element of $\mathbb{Z}_{\geq 0}\tau^{[0]}$) to $0 \in \mathbb{C}$. To prove the proposition, it suffices to show that this extends to a monoid map $M \cap \mathbb{R}_{\geq 0}\tau \rightarrow \mathbb{C}$ in a unique way. Indeed, we can define such an extension by sending 0 to 1 , and each nonzero element of $M \cap \mathbb{R}_{\geq 0}\tau$ to 0 . This extension is unique as $M \cap \mathbb{R}_{\geq 0}\tau$ is contained in $\mathbb{Q}\tau^{[0]}$. \square

Since the D_τ -invariant ring $\mathbb{C}[\mathbb{Z}_{\geq 0}\tau^{[0]}]$ is a polynomial ring, we may endow it with a grading by declaring that $\deg(z^m) = 1$ whenever m is a vertex of τ .

Definition 2.12 Let $0 \in Y_{0,\tau}$ and let $0 \in \text{Spec}(\mathbb{C}[\mathbb{Z}_{\geq 0}\tau^{[0]}])$ denote the points of [Proposition 2.11](#). We define a space $\mathbb{P}^{\dim(\tau)}$ and a map $\pi_\tau: Y_{0,\tau} \setminus \{0\} \rightarrow \mathbb{P}^{\dim(\tau)}$ as follows.

- (1) We let $\mathbb{P}^{\dim(\tau)} = \text{Proj}(\mathbb{C}[\mathbb{Z}_{\geq 0}\tau^{[0]}])$, where the grading on the coordinate ring is indicated above. In other words, $\mathbb{P}^{\dim(\tau)}$ is a projective space whose homogeneous coordinates are naturally indexed by the vertices of τ .
- (2) We let $q_\tau: Y_{0,\tau} \setminus \{0\} \rightarrow \mathbb{P}^{\dim(\tau)}$ denote the composite map

$$Y_{0,\tau} \setminus \{0\} \rightarrow \mathbb{C}^{\dim(\tau)+1} \setminus \{0\} \rightarrow \mathbb{P}^{\dim(\tau)},$$

where the first map is the D_τ -quotient map of [Proposition 2.10](#) and the second map is the tautological map.

Note the abuse of notation in (1): if $\dim(\tau) = \dim(\tau')$ we will usually regard $\mathbb{P}^{\dim(\tau)}$ as different from $\mathbb{P}^{\dim(\tau')}$.

2.2 Degeneration of the hypersurface

In [Proposition 2.5](#), we have seen that the general fiber of $\pi: Y \rightarrow \mathbb{A}^1$ is isomorphic to $\text{Spec } \mathbb{C}[M \cap \mathbb{R}_{\geq 0}\Delta]$. We now describe a degeneration of $\bar{V}(f) \subseteq \text{Spec } \mathbb{C}[(\mathbb{R}_{\geq 0}\Delta) \cap M]$ contained in the family $\pi: Y \rightarrow \mathbb{A}^1$. The total space of the degeneration is the hypersurface in Y cut out by a regular function \tilde{f} on Y . On the open orbit of Y , \tilde{f} looks like

$$\tilde{f} = a_0 + \sum_{m \in \mathcal{T}^{[0]}} a_m z^{(m,h(m))} = a_0 + \sum_{m \in \mathcal{T}^{[0]}} a_m z^m t^{h(m)},$$

where the a_m are the same coefficients as in f ; see [Equation \(2-1\)](#). Denote the vanishing locus of \tilde{f} by $X = V(\tilde{f})$.

Remark 2.13 When 0 is in the interior of Δ , X is a degeneration of $V(f)$. When 0 is on the boundary, X is a degeneration of $\bar{V}(f) \supset V(f)$ defined in [Remark 2.2](#).

Example 2.14 We return to the setting of [Example 2.7](#) to study the associated degeneration of the smooth hypersurface defined by the polynomial $f = -1 + x^2 + xy + y^2$. Note that $\text{Spec } \mathbb{C}[(\mathbb{R}_{\geq 0}\Delta) \cap M] \cong \mathbb{C}^2$, so we will degenerate both $\bar{V}(f)$ and inside it $Z = V(f) \subseteq \mathbb{C}^* \times \mathbb{C}^*$. In [Example 3.5](#) we shall study the skeleton of Z , and in [Example 5.7](#) we will turn to investigate the skeleton of $\bar{V}(f)$ in \mathbb{C}^2 .

The function $\tilde{f}: Y \rightarrow \mathbb{C}$ is written $\tilde{f} = -1 + b + d + e$. Recalling from [Example 2.7](#) that $b = z^{(2,0)}t^{h(2,0)} = x^2t^2$, $d = z^{(1,1)}t^{h(1,1)} = xyt$, and $e = z^{(0,2)}t^{h(0,2)} = y^2t^2$, we see that \tilde{f} specializes to f on $\pi^{-1}(1)$.

The restriction of \tilde{f} to $Y_{0,\tau}$ is the image of \tilde{f} under the ring quotient map

$$\mathbb{C}[\Gamma_{\geq h} \cap \tilde{M}] \rightarrow \mathbb{C}[\Gamma_{\geq h,\tau} \cap \tilde{M}]$$

that carries $z^{(m,r)}$ to itself if $(m, r) \in \Gamma_{\geq h,\tau}$ and to 0 otherwise. In other words, $\tilde{f}|_{Y_{0,\tau}}$ is given by

$$\tilde{f}|_{Y_{0,\tau}} = a_0 + \sum_{m \in \tau^{[0]}} a_m z^{(m,h(m))}.$$

Let us denote the image of $\tilde{f}|_{Y_{0,\tau}}$ under the identification $Y_{0,\tau} = \text{Spec } \mathbb{C}[\mathbb{R}\tau \cap M]$ by f_τ . We record this in the following definition.

Definition 2.15 Let a_m be the coefficients of f ; see [Equation \(2-1\)](#).

- (1) Let $f_\tau \in \mathbb{C}[\mathbb{R}_{\geq 0}\tau \cap M]$ denote the expression

$$f_\tau = a_0 + \sum_{m \in \tau^{[0]}} a_m z^m$$

regarded as a regular function on $Y_{0,\tau}$. Let $X_{0,\tau}$ be the hypersurface in $Y_{0,\tau}$ cut out by f_τ .

- (2) Let $\ell_\tau \in \mathbb{C}[\mathbb{Z}_{\geq 0}\tau^{[0]}]$ denote the expression

$$\ell_\tau = \sum_{m \in \tau^{[0]}} a_m z^m$$

regarded as a homogeneous linear function on $\mathbb{P}^{\dim(\tau)}$. Let $V(\ell_\tau) \subseteq \mathbb{P}^{\dim(\tau)}$ denote the hyperplane cut out by ℓ_τ .

Proposition 2.16 Fix $\tau \in \mathcal{T}$ and denote by $p_\tau: X_{0,\tau} \rightarrow \mathbb{P}^{\dim(\tau)}$ the composition

$$X_{0,\tau} \hookrightarrow Y_{0,\tau} \setminus \{0\} \xrightarrow{q_\tau} \mathbb{P}^{\dim(\tau)},$$

where the second map is the projection of [Definition 2.12](#). Then

- (1) p_τ is a finite proper surjection onto the affine space $\mathbb{P}^{\dim(\tau)} \setminus V(\ell_\tau) \cong \mathbb{C}^{\dim(\tau)}$,
- (2) p_τ induces an isomorphism

$$X_{0,\tau}/D_\tau \cong \mathbb{P}^{\dim(\tau)} \setminus V(\ell_\tau),$$

where D_τ is as in [Definition 2.9](#),

- (3) the ramification locus of p_τ is contained in the coordinate hyperplanes of $\mathbb{P}^{\dim(\tau)}$.

Proof The following implicit assertions of the proposition are trivial to verify.

- Since $a_0 \neq 0$, the point $0 \in Y_{0,\tau}$ of Proposition 2.11 does not lie on $X_{0,\tau}$.
- Since the monomials that appear in f_τ belong to $\mathbb{Z}_{\geq 0}\tau^{[0]}$, they are invariant under the action of D_τ . In particular $X_{0,\tau}$ is invariant under D_τ .

Note that (1) is a consequence of (2). Since $a_0 \neq 0$ the function $f_\tau = a_0 + \ell_\tau$ cannot vanish anywhere that ℓ_τ vanishes. Therefore the image of p_τ is contained in $\mathbb{P}^{\dim(\tau)} \setminus V(\ell_\tau)$. To complete the proof of (2), let us show that the affine coordinate ring R_1 of $\mathbb{P}^{\dim(\tau)} \setminus V(\ell_\tau)$ is the D_τ -invariant subring of the affine coordinate ring R_2 of $X_{0,\tau}$. We have

$$R_1 = \mathbb{C}[\mathbb{Z}_{\geq 0}\tau^{[0]}]/(a_0 + \ell_\tau),$$

$$R_2 = \mathbb{C}[M \cap \mathbb{R}_{\geq 0}\tau]/(f_\tau),$$

and the short exact sequences

$$0 \longrightarrow \mathbb{C}[\mathbb{Z}_{\geq 0}\tau^{[0]}] \xrightarrow{a_0 + \ell_\tau} \mathbb{C}[\mathbb{Z}_{\geq 0}\tau^{[0]}] \longrightarrow R_1 \longrightarrow 0,$$

$$0 \longrightarrow \mathbb{C}[M \cap \mathbb{R}_{\geq 0}\tau] \xrightarrow{f_\tau} \mathbb{C}[M \cap \mathbb{R}_{\geq 0}\tau] \longrightarrow R_2 \longrightarrow 0.$$

Note that since D_τ is finite, and we are working in characteristic zero, taking D_τ -invariants preserves short exact sequences. Part (2) of the proposition is a consequence of this observation and the fact that $\mathbb{C}[\mathbb{Z}_{\geq 0}\tau] = \mathbb{C}[M \cap \mathbb{R}_{\geq 0}\tau]^{D_\tau}$ by Proposition 2.10.

Now let us prove (3). Let $H \subseteq \mathbb{P}^{\dim(\tau)}$ be the union of coordinate hyperplanes. By (2), to show that p_τ is unramified away from H it suffices to show that D_τ acts freely on $X_{0,\tau}$ away from $p_\tau^{-1}(H)$. In fact D_τ acts freely on $Y_{0,\tau} \setminus q_\tau^{-1}(H)$. This completes the proof. □

2.3 Degeneration of the compact hypersurface

The families $\pi: Y \rightarrow \mathbb{A}^1$ and $\pi: X \rightarrow \mathbb{A}^1$ of Sections 2.1 and 2.2 have fairly natural algebraic relative compactifications (ie “properifications” of the maps π) that we review here.

We define the polyhedron

$$\bar{\Gamma} = \{(m, r) \in \tilde{M}_{\mathbb{R}} \mid m \in \Delta, r \geq h(m)\},$$

which is contained in $\Gamma_{\geq h}$. We set $\tilde{N} = \text{Hom}(\tilde{M}, \mathbb{Z})$, $\tilde{N}_{\mathbb{R}} = \tilde{N} \otimes_{\mathbb{Z}} \mathbb{R}$. The normal fan of $\bar{\Gamma}$ is the fan $\Sigma_{\bar{\Gamma}} = \{\sigma_\tau \mid \tau \subseteq \bar{\Gamma}\}$ where

$$\sigma_\tau = \{n \in \tilde{N}_{\mathbb{R}} \mid \langle m - m', n \rangle \geq 0 \text{ for all } m \in \bar{\Gamma}, m' \in \tau\}$$

and $\langle \cdot, \cdot \rangle: \widetilde{M} \otimes \widetilde{N} \rightarrow \mathbb{Z}$ is the natural pairing. Let \bar{Y} denote the toric variety associated to $\Sigma_{\bar{\Gamma}}$. It is covered by the set of affine open charts of the shape $\text{Spec } \mathbb{C}[\sigma_{\tau}^{\vee} \cap \widetilde{M}]$, where $\tau \in \bar{\Gamma}^{[0]}$ and

$$\sigma_{\tau}^{\vee} = \mathbb{R}_{\geq 0}\{m - m' \mid m \in \bar{\Gamma}, m' \in \tau\} \subseteq \widetilde{M}_{\mathbb{R}}$$

is the dual cone of σ_{τ} . Note that $\sigma_0^{\vee} = \Gamma_{\geq h}$, so we have an open embedding $Y \subseteq \bar{Y}$. Since $(0, 1) \in \sigma_{\tau}^{\vee}$ for all $\tau \subseteq \bar{\Gamma}$, π extends to a regular function

$$\pi: \bar{Y} \rightarrow \mathbb{A}^1.$$

The support of $\Sigma_{\bar{\Gamma}}$ is $\{(n, r) \in \widetilde{N}_{\mathbb{R}} \mid r \geq 0\}$ and pairing with the monomial $(0, 1)$ sends this to $\mathbb{R}_{\geq 0}$. Thus by the proposition in Section 2.4 of [14], we have the following.

Lemma 2.17 *We have that $\pi: \bar{Y} \rightarrow \mathbb{A}^1$ is proper.*

Corollary 2.18 *Let \bar{X} denote the closure of X in \bar{Y} . Then $\pi: \bar{X} \rightarrow \mathbb{A}^1$, the restriction of π to \bar{X} , is proper.*

3 The skeleton

3.1 Definition of the skeleton

We adopt the notation from Section 2, in particular that $M \cong \mathbb{Z}^{n+1}$ is a lattice and $\Delta \subseteq M_{\mathbb{R}} = M \otimes_{\mathbb{Z}} \mathbb{R}$ a lattice polytope containing 0 and with regular lattice triangulation \mathcal{T} of $\partial\Delta'$. For $x \in \partial\Delta'$, let us denote by τ_x the lowest-dimensional simplex of \mathcal{T} containing x .

Definition 3.1 With Δ , \mathcal{T} , and $x \mapsto \tau_x$ given as above, define the topological subspace

$$S_{\Delta, \mathcal{T}} \subseteq \partial\Delta' \times \text{Hom}(M, S^1)$$

to be the set of pairs (x, ϕ) satisfying

$$\phi(v) = 1 \in S^1 \quad \text{whenever } v \in M \text{ is a vertex of } \tau_x.$$

The fibers of the projection $S_{\Delta, \mathcal{T}} \rightarrow \partial\Delta$ are constant above the interior of each simplex of \mathcal{T} . In fact these fibers are naturally identified with a subgroup of the torus $\text{Hom}(M, S^1)$. Let us introduce some notation for these fibers.

Definition 3.2 For each simplex $\tau \in \mathcal{T}$, let G_τ denote the commutative group contained in the torus $\text{Hom}(M, S^1)$ given by

$$G_\tau := \{\phi \in \text{Hom}(M, S^1) \mid \phi(v) = 1 \text{ whenever } v \in M \text{ is a vertex of } \tau\}.$$

We denote the identity component of G_τ by A_τ and denote the discrete quotient $G_\tau/A_\tau = \pi_0(G_\tau)$ by D_τ . That is, we have the short exact sequence of abelian groups

$$(3-1) \quad 1 \rightarrow A_\tau \rightarrow G_\tau \rightarrow D_\tau \rightarrow 1.$$

We can also obtain this sequence by applying the exact contravariant functor $\text{Hom}(\cdot, S^1)$ to the sequence

$$0 \leftarrow M/((\mathbb{R}\tau) \cap M) \leftarrow M/(\mathbb{Z}\tau^{[0]}) \leftarrow ((\mathbb{R}\tau) \cap M)/(\mathbb{Z}\tau^{[0]}) \leftarrow 0.$$

On finite groups, $\text{Hom}(\cdot, S^1) = \text{Hom}(\cdot, \mathbb{C}^*)$, so the definition of D_τ given here agrees with [Definition 2.9](#). Here are two additional properties of the groups G_τ :

- (1) A_τ is a compact torus of dimension $n - \dim(\tau)$.
- (2) When $\tau' \subseteq \tau$, there is a reverse containment $G_\tau \subseteq G_{\tau'}$.

Remark 3.3 The fiber of $S_{\Delta, \mathcal{T}} \rightarrow \partial\Delta'$ above x is connected if and only if D_{τ_x} is trivial, so if and only if the simplex $\text{conv}(\{0\} \cup \tau_x)$ is unimodular. A triangulation whose simplices are unimodular uses every lattice point of Δ as a vertex, but the converse is not true. For instance, τ might contain a triangle of the form $\{(1, 0, 0), (0, 1, 0), (1, 1, N)\}$ for $N > 1$.

Remark 3.4 Define an equivalence relation on $\widehat{S}_{\Delta, \mathcal{T}}$ by setting $x \sim y$ if both of the following hold.

- x and y project to the same element of $\partial\Delta'$.
- x and y are in the same connected component of the fiber of this projection.

If \mathcal{T} is unimodular, then the quotient $S_{\Delta, \mathcal{T}}/\sim$ is just $\partial\Delta'$. In general $\partial\Delta'$ is some branched cover of $\partial\Delta'$, with stratum τ° having covering group D_τ . We may write it as a regular cell complex which we denote by $\widehat{\partial\Delta'}$, ie

$$\widehat{\partial\Delta'} := S_{\Delta, \mathcal{T}}/\sim \cong \bigcup_{\tau \in \mathcal{T}} \tau^\circ \times D_\tau.$$

We investigate this in more detail in the [Section 3.2](#).

Example 3.5 Picking up from [Example 2.14](#), we consider $Z = V(f)$ in $\mathbb{C}^* \times \mathbb{C}^*$ and compute its skeleton. We write $\phi \in \text{Hom}(\mathbb{Z}^2, \mathbb{R}/\mathbb{Z})$ as $\phi = (\alpha, \beta)$, where $\phi(u, v) = \alpha u + \beta v \pmod{\mathbb{Z}}$. The vertex $\{b\} = \{(2, 0)\} \in \mathcal{T}$ has $G_{\{b\}} = \{(\alpha, \beta) \mid 2\alpha \equiv 0\}$ which is isomorphic to $\mathbb{Z}/2 \times \mathbb{R}/\mathbb{Z}$ — namely α is 0 or $1/2$ and β is free — which is homeomorphic to two disjoint circles. Similarly, $G_{\{e\}}$ is two disjoint circles: α is free and β is 0 or $1/2$. $G_{\overline{bd}} = G_{\overline{de}} \cong \mathbb{Z}/2$ is two points: $(\alpha, \beta) = (0, 0)$ or $(\frac{1}{2}, \frac{1}{2})$. We have that $G_{\{d\}}$ is a single circle, $\beta = -\alpha$, since d is primitive. Up to homotopy, the fibers over the edges serve to attach the circles over b and e to $G_{\{d\}}$, meaning $S_{\Delta, \mathcal{T}}$ is homotopic to a bouquet of five circles. A schematic representation of $S_{\Delta, \mathcal{T}}$ is given below.

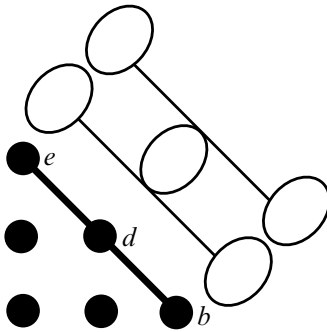

We shall see that Z is homotopy equivalent to $S_{\Delta, \mathcal{T}}$ after investigating the skeleton of $\overline{V}(f)$ in [Example 5.7](#) in [Section 5](#).

Remark 3.6 The vertices of the triangulation \mathcal{T} generate the rays of a (stacky) fan $\Sigma^\vee \subseteq M_{\mathbb{R}}$. It is shown by Fang, Liu and the third and fourth authors in [\[11; 12\]](#) that coherent sheaves on the toric Deligne–Mumford stack associated with Σ^\vee can be regarded as constructible sheaves on a compact torus with singular support in a conic Lagrangian $\Lambda_{\Sigma^\vee} \subseteq N_{\mathbb{R}}/N \times M_{\mathbb{R}} \cong T^*(N_{\mathbb{R}}/N)$. This “coherent-constructible correspondence” is a full embedding of triangulated categories, conjecturally an equivalence. The conic Lagrangian Λ_{Σ^\vee} is noncompact. Its Legendrian “boundary” $\Lambda_{\Sigma^\vee}^\infty$ at contact infinity of $T^*(N_{\mathbb{R}}/N)$ is homeomorphic to $S_{\Delta, \mathcal{T}}$; see also [Section 1.3](#).

3.2 The cell complex $\widehat{\partial \Delta'}$ as a regular cell complex

Let us describe the combinatorics of $\widehat{\partial \Delta'}$ in some more detail.

Definition 3.7 For each $\tau \in \mathcal{T}$ let D_τ be the finite commutative group given in [Definition 2.9](#). We define the partially ordered set $\widehat{\mathcal{T}}$ as follows.

- (1) If $\tau, \tau' \in \mathcal{T}$ have $\tau \subseteq \tau'$, define a homomorphism $\text{res}_{\tau',\tau}: D_{\tau'} \rightarrow D_{\tau}$ by the following formula. If $d: \mathbb{R}\tau' \cap M \rightarrow S^1$ is an element of $D_{\tau'}$, then $\text{res}_{\tau',\tau}(d): \mathbb{R}\tau \cap M \rightarrow S^1$ is given by

$$\text{res}_{\tau',\tau}(d)(m) = d(m).$$

- (2) Let $\widehat{\mathcal{T}}$ denote the set of pairs (τ, d) where $\tau \in \mathcal{T}$ and $d \in D_{\tau}$. We regard $\widehat{\mathcal{T}}$ as a partially ordered set with partial order given by

$$(\tau, d) \leq (\tau', d') \quad \text{whenever } \tau \subseteq \tau' \text{ and } \text{res}_{\tau',\tau}(d') = d.$$

Each $(\tau, d) \in \widehat{\mathcal{T}}$ determines a map

$$i_{\tau,d}: \tau \rightarrow \widehat{\partial\Delta'}$$

by the formula

$$i_{\tau,d}(m) = \{m\} \times d.$$

Proposition 3.8 *For each $\tau \in \mathcal{T}$ and $d \in D_{\tau}$, and let $i_{\tau,d}$ be the map defined above. The following hold.*

- (1) *For each $\tau \in \mathcal{T}$ and $d \in D_{\tau}$, the map $i_{\tau,d}$ is a homeomorphism of τ onto its image $i_{\tau,d}(\tau) \subseteq \widehat{\partial\Delta'}$.*
 (2) *For any face $\tau' \subseteq \tau$, the restriction of $i_{\tau,d}$ to τ' coincides with $i_{\tau',d'}$ for some $d' \in D_{\tau'}$.*

In other words, $\widehat{\partial\Delta'}$ is a regular cell complex whose partially ordered set of cells is naturally isomorphic to $\widehat{\mathcal{T}}$.

Proof Note that the composite $\tau \rightarrow \widehat{\partial\Delta'} \rightarrow \partial\Delta'$ is the usual inclusion of τ into $\partial\Delta'$; in particular $\tau \rightarrow i_{\tau,d}(\tau)$ is a continuous bijection. Since τ is compact and $\widehat{\partial\Delta'}$ is Hausdorff, this proves (1). For (2), simply put $d' = \text{res}_{\tau,\tau'}(d)$. □

Remark 3.9 In fact the proposition shows $\widehat{\partial\Delta'}$ is a “ Δ -complex” in the sense of Hatcher [18, 2.1], or a “generalized simplicial complex” in the sense of Kozlov [23, Definition 2.41].

Remark 3.10 We will use the following device for constructing continuous maps out of $\widehat{\partial\Delta'}$ or X_0 .

- (1) Let K be a regular cell complex, let $\{\kappa\}$ be the poset of cells, and let L be a topological space. If $\{j_{\kappa}: \kappa \rightarrow L\}$ is a system of continuous maps such that $j_{\kappa}|_{\kappa'} = j_{\kappa'}$ whenever $\kappa' \subseteq \kappa$, then there is a unique continuous map $j: K \rightarrow L$ with $j|_{\kappa} = j_{\kappa}$ for all κ .

- (2) Let L be a topological space. If $\{j_\tau: X_{0,\tau} \rightarrow L\}_{\tau \in \mathcal{T}}$ is a system of continuous maps such that $j_\tau|_{\tau'} = j_{\tau'}$ whenever $\tau' \subseteq \tau$, then there is a unique continuous map $j: X_0 \rightarrow L$ with $j|_\tau = j_\tau$ for all τ .

In other words, K is a colimit of its cells and X_0 is a colimit of the components $X_{0,\tau}$.

Remark 3.11 For each $\tau \in \mathcal{T}$, $i_{\tau,1}$ be the embedding $\tau \hookrightarrow \widehat{\partial\Delta'}$, where the “1” in the subscript indicates the identity element of D_τ . These assemble to an inclusion $\partial\Delta' \hookrightarrow \widehat{\partial\Delta'}$ by Remark 3.10.

3.2.1 The homotopy type of $\widehat{\partial\Delta'}$ It is easy to identify the homotopy type of $\widehat{\partial\Delta'}$, using the technique of “shelling.”

Theorem 3.12 *The regular cell complex $\widehat{\partial\Delta'}$ has the homotopy type of a wedge of n -dimensional spheres.*

Proof We will show that $\widehat{\partial\Delta'}$ is *shellable* in the sense of [23, Definition 12.1]; then by [23, Theorem 12.3] $\widehat{\partial\Delta'}$ is homotopy equivalent to a wedge of n -dimensional spheres. By Brugger and Mani [7, Proposition 1], the triangulation \mathcal{T} of $\partial\Delta'$ has a shellable subdivision, denote it by \mathcal{S} . Let $\widehat{\mathcal{S}}$ denote the lift of \mathcal{S} to $\widehat{\partial\Delta'}$. For each top-dimensional face σ of \mathcal{S} , fix a total order $F(\sigma, 1), \dots, F(\sigma, k)$ of the top-dimensional faces of $\widehat{\mathcal{S}}$ that lie above σ . Since $\widehat{\partial\Delta'} \rightarrow \partial\Delta'$ is a branched covering along the simplices of \mathcal{S} , whenever $\sigma_1, \sigma_2, \dots, \sigma_N$ is a shelling of \mathcal{S} then

$$F(\sigma_1, 1), \dots, F(\sigma_1, k_1), F(\sigma_2, 1), F(\sigma_2, 2), \dots, F(\sigma_2, k_2), \dots, F(\sigma_N, 1), \dots, F(\sigma_N, k_N)$$

is a shelling of $\widehat{\mathcal{S}}$. □

3.3 Embedding $\widehat{\partial\Delta'}$ into X_0

In this section, using the positivity conditions on the coefficients a_m of f described below (2-1), we will construct an embedding of $\widehat{\partial\Delta'}$ into the special fiber X_0 .

3.3.1 General remarks on positive loci in toric varieties Let $T \cong (\mathbb{C}^*)^n$ be an algebraic torus and fix a splitting $T \cong \text{U}(1)^n \times \mathbb{R}_{>0}^n$. If W is a toric variety acted on by T , and $1 \in W$ is a base point in the open orbit, then the *positive locus* of W is the $\mathbb{R}_{>0}^n$ -orbit of 1 on W . The *nonnegative locus* is the closure of the positive locus in W . We write $W_{>0}$ for the positive locus and $W_{\geq 0}$ for the nonnegative locus.

Example 3.13 Let W be an affine toric variety of the form $\text{Spec}(\mathbb{C}[M \cap \sigma])$. Then under the identification $W \cong \text{Hom}(M \cap \sigma, \mathbb{C})$ of Proposition 1.8, the nonnegative locus is

$$(3-2) \quad W_{\geq 0} \cong \text{Hom}(M \cap \sigma, \mathbb{R}_{\geq 0}).$$

When $W = \text{Proj}(\mathbb{C}[\mathbb{Z}_{\geq 0}^{n+1}])$, the nonnegative locus is the set of points whose homogeneous coordinates can be chosen to be nonnegative real numbers. It can be identified with a simplex. The following proposition investigates this example in more detail.

Proposition 3.14 Let $\tau \subseteq M_{\mathbb{R}}$ be a lattice simplex, and let $\mathbb{P}^{\dim(\tau)}$ be the projective space of Definition 2.12. Let $[x_m]_{m \in \tau^{[0]}}$ be homogeneous coordinates for a point of $\mathbb{P}^{\dim(\tau)}$. Define the moment map $\mu_{\tau}: \mathbb{P}^{\dim(\tau)} \rightarrow M_{\mathbb{R}}$ by

$$\mu_{\tau}([x_m]_{m \in \tau^{[0]}}) = \frac{\sum_{m \in \tau^{[0]}} |x_m|^2 m}{\sum_{m \in \tau^{[0]}} |x_m|^2}.$$

Then μ_{τ} is a homeomorphism of $\mathbb{P}_{\geq 0}^{\dim(\tau)}$ onto τ .

Proof See [14, Section 4.2]. □

Remark 3.15 The map of Proposition 3.14 is the usual moment map for a Hamiltonian torus action and symplectic form on $\mathbb{P}^{\dim(\tau)}$, but the conclusion of the proposition holds for any map of the form

$$\frac{\sum_{m \in \tau^{[0]}} |x_m|^e m}{\sum_{m \in \tau^{[0]}} |x_m|^e}$$

so long as e is real and $e > 0$. When $e > 1$, these maps are smooth. The case $e = 1$ may lead to a simpler formula for the map considered in Definition 4.19

Remark 3.16 The moment maps of Proposition 3.14 have the following compatibility feature: if $\tau' \subseteq \tau$ is a face of τ , then the restriction of μ_{τ} to $\mathbb{P}^{\dim(\tau')} \subseteq \mathbb{P}^{\dim(\tau)}$ is $\mu_{\tau'}$. In particular by Remark 3.10, there is a well-defined map

$$\nu: X_0 \rightarrow \partial \Delta' \subseteq M_{\mathbb{R}},$$

such that, for all τ , its restriction to $X_{0,\tau}$ is given by $\nu_{\tau} := \mu_{\tau} \circ p_{\tau}$.

3.3.2 Embedding Recall the D_{τ} -equivariant maps

$$p_{\tau}: X_{0,\tau} \rightarrow \mathbb{P}^{\dim(\tau)} \setminus V(\ell_{\tau})$$

of Proposition 2.16. We use it to define a nonnegative locus in $X_{0,\tau}$.

Definition 3.17 Fix $\tau \in \mathcal{T}$. Let $\mathbb{P}^{\dim(\tau)}$ be the projective space of Definition 2.12 and let $X_{0,\tau}$ be the affine variety of Definition 2.15. We define subsets

$$\mathbb{P}_{>0}^{\dim(\tau)} \subseteq \mathbb{P}_{\geq 0}^{\dim(\tau)} \subseteq \mathbb{P}^{\dim(\tau)},$$

$$(X_{0,\tau})_{>0} \subseteq (X_{0,\tau})_{\geq 0} \subseteq X_{0,\tau}$$

as follows.

- (1) Let $\mathbb{P}_{>0}^{\dim(\tau)} \subseteq \mathbb{P}^{\dim(\tau)}$ be the set of points whose homogeneous coordinates can be chosen to be positive real numbers. We call $\mathbb{P}_{>0}^{\dim(\tau)}$ the *positive locus* of $\mathbb{P}^{\dim(\tau)}$.
- (2) Let $\mathbb{P}_{\geq 0}^{\dim(\tau)} \subseteq \mathbb{P}^{\dim(\tau)}$ be the closure of $\mathbb{P}_{>0}^{\dim(\tau)}$, ie the set of points whose homogeneous coordinates can be chosen to be nonnegative real numbers. We call $\mathbb{P}_{\geq 0}^{\dim(\tau)}$ the *nonnegative locus* of $\mathbb{P}^{\dim(\tau)}$.
- (3) If $(Y_{0,\tau})_{\geq 0}$ is as defined in Example 3.13, let $(X_{0,\tau})_{\geq 0} = X_{0,\tau} \cap (Y_{0,\tau})_{\geq 0}$.

Proposition 3.18 Let $\mathbb{P}_{\geq 0}^{\dim(\tau)}$ and $V(\ell_\tau)$ be as in Definition 3.17 and Definition 2.15, respectively. The following hold.

- (1) The hyperplane $V(\ell_\tau)$ does not meet $\mathbb{P}_{\geq 0}^{\dim(\tau)}$, ie

$$V(\ell_\tau) \cap \mathbb{P}_{\geq 0}^{\dim(\tau)} = \emptyset.$$
- (2) The projection of $X_{0,\tau}$ onto $\mathbb{P}^{\dim(\tau)} \setminus V(\ell_\tau)$ induces a homeomorphism of nonnegative loci

$$(X_{0,\tau})_{\geq 0} \xrightarrow{\sim} \mathbb{P}_{\geq 0}^{\dim(\tau)}.$$

Proof Suppose $[x_m]_{m \in \tau^{[0]}}$ are homogeneous coordinates for a point $P \in \mathbb{P}^{\dim(\tau)}$. If P belongs to the nonnegative locus, then by definition we may choose the x_m to be real and nonnegative. Moreover, at least one of the x_m must be nonzero, say x_{m_0} . Then evaluating ℓ_τ on P gives

$$\ell_\tau(P) = \sum_{m \in \tau^{[0]}} a_m x_m \geq a_{m_0} x_{m_0} > 0$$

since all the a_m are positive real numbers. In particular $\ell_\tau(P) \neq 0$. This proves (1).

Let us prove (2). Let $v_0, \dots, v_{\dim(\tau)}$ be the vertices of τ . A point of $(Y_{0,\tau})_{\geq 0}$ is given by a monoid homomorphism $x: M \cap \mathbb{R}_{\geq 0}\tau \rightarrow \mathbb{R}_{\geq 0}$. Since $\mathbb{R}_{\geq 0}$ is divisible and $\tau^{[0]}$ is a basis for $\mathbb{R}\tau$, x is determined by its values on $\tau^{[0]}$, and the map

$$x \mapsto (x(v_0), \dots, x(v_{\dim(\tau)}))$$

is a homeomorphism of $(Y_{0,\tau})_{\geq 0}$ onto $\mathbb{R}_{\geq 0}^{\dim(\tau)+1}$. In these coordinates, the equation $f_\tau = 0$ defining $(X_{0,\tau})_{\geq 0}$ is

$$\sum_{i=0}^{\dim(\tau)} a_{v_i} x(v_i) = -a_0,$$

which (since $a_0 < 0$ and $a_{v_i} > 0$) is a simplex with a vertex on each coordinate ray of $\mathbb{R}_{\geq 0}^{\dim(\tau)+1}$. It follows that the projection onto $(\mathbb{R}_{\geq 0}^{\dim(\tau)+1} \setminus \{0\})/\mathbb{R}_{>0} \cong \mathbb{P}_{\geq 0}^{\dim(\tau)}$ is a homeomorphism. \square

To define an embedding $\widehat{\partial\Delta'} \rightarrow X_0$, we may appeal to [Remark 3.10](#) and define map it simplex by simplex.

Definition 3.19 Let $\widehat{\mathcal{T}}$ be the poset of [Definition 3.7](#). For each $(\tau, d) \in \widehat{\mathcal{T}}$ define the map $j_{\tau,d}$ to be the composite

$$\tau \xrightarrow{\mu^{-1}} \mathbb{P}_{\geq 0}^{\dim(\tau)} \xrightarrow{p_\tau^{-1}} (X_{0,\tau})_{\geq 0} \xrightarrow{d} X_{0,\tau},$$

where

- μ^{-1} is the inverse homeomorphism to the map of [Proposition 3.14](#),
- p_τ^{-1} is the inverse homeomorphism to the map of [Proposition 3.18\(2\)](#),
- d denotes the action of $d \in D_\tau$ on $X_{0,\tau}$ of [Definition 2.9](#).

Proposition 3.20 Let $\widehat{\partial\Delta'}$ be as in [Remark 3.4](#), let $\widehat{\mathcal{T}}$ be as in [Definition 3.7](#), and for each $(\tau, d) \in \widehat{\mathcal{T}}$ let $i_{\tau,d}: \tau \hookrightarrow \widehat{\partial\Delta'}$ be the inclusion defined in [Section 3.2](#) and let $j_{\tau,d}$ be the inclusion of [Definition 3.19](#). There is a unique map $j: \widehat{\partial\Delta'} \hookrightarrow X_0$ such that for all $(\tau, d) \in \widehat{\mathcal{T}}$, the square

$$\begin{array}{ccc} \tau & \xrightarrow{j_{\tau,d}} & X_{0,\tau} \\ i_{\tau,d} \downarrow & & \downarrow \\ \widehat{\partial\Delta'} & \xrightarrow{j} & X_0 \end{array}$$

commutes.

Proof By [Remark 3.10\(1\)](#), it suffices to show that the maps $\tau \rightarrow X_0$ given by $j_{\tau,d}$ are compatible in the sense that $j_{\tau,d}|_{\tau'} = j_{\tau', \text{res}_{\tau,\tau'}(d)}$ whenever $\tau' \subseteq \tau$. To see this, note that if $t' \in \tau' \subseteq \tau$, then μ^{-1} carries t' to $\mathbb{P}_{\geq 0}^{\dim \tau'} \subseteq \mathbb{P}_{\geq 0}^{\dim \tau}$; see [Remark 3.16](#). The proof of [Proposition 3.18](#) shows that $p_{\tau'}^{-1}$ and p_τ^{-1} agree on this locus. Finally, the actions of d and $\text{res}_{\tau,\tau'}(d)$ are defined to agree on the result. \square

Remark 3.21 The inverse image above $\tau \subseteq \partial\Delta'$ of the map $\widehat{\partial\Delta'} \rightarrow \partial\Delta'$ is a mild generalization (to Fermat hypersurfaces in weighted projective spaces) of the space considered in [10, pages 88–90].

3.4 The cell complex $\widehat{\partial\Delta'}$ embeds in X_0 as a deformation retract

In this section we prove that the inclusion $\widehat{\partial\Delta'} \hookrightarrow X_0$ is a deformation retract. This is a “degenerate” case of our Main Theorem, and plays an important role in the proof.

3.4.1 Lifting deformation retractions along branched covers Let us first discuss a path-lifting property of branched coverings.

Definition 3.22 Let W be a locally contractible, locally compact Hausdorff space and let $F_1 \subseteq F_2 \subseteq \dots \subseteq F_k \subseteq W$ be a filtration by closed subsets.

- (1) A map $p: W' \rightarrow W$ is *branched along the filtration F* if it is proper and if $p^{-1}(F_i \setminus F_{i-1}) \rightarrow F_i \setminus F_{i-1}$ is a covering space for every i .
- (2) A path $\gamma: [0, 1] \rightarrow W$ is called an *enter path for the filtration F* if whenever $\gamma(t) \in F_i$, then $\gamma(s) \in F_i$ for all $s > t$. (In other words once γ enters the subset F_i , it does not leave.) Write $\text{Maps}_F([0, 1], W)$ for the space of enter paths for F , with the compact open topology.
- (3) An *F -deformation retraction* is a deformation retraction $W \rightarrow \text{Maps}([0, 1], W)$ that factors through $\text{Maps}_F([0, 1], W)$.

Proposition 3.23 Let $p: W' \rightarrow W$ be branched along a filtration F of W . Let $\gamma: [0, 1] \rightarrow W$ be an enter path for F . Then for each $w' \in p^{-1}(\gamma(0))$, there is a unique path $\tilde{\gamma}: [0, 1] \rightarrow W'$ with $p \circ \tilde{\gamma} = \gamma$ and $\tilde{\gamma}(0) = w'$. The path $\tilde{\gamma}$ is an enter path for $p^{-1}(F)$, and the map

$$W' \times_{p, W, \text{ev}_0} \text{Maps}_F([0, 1], W) \rightarrow \text{Maps}_{p^{-1}(F)}([0, 1], W')$$

that sends (w', γ) to the unique lift $\tilde{\gamma}$ is continuous.

Proof This follows by a modification of the standard argument for covering spaces; see Woolf [30, Proposition 4.2] and also Fox [13]. □

Corollary 3.24 Suppose $p: W' \rightarrow W$ is branched along a filtration F of W . Suppose that $r: W \rightarrow \text{Maps}_F([0, 1], W)$ is an F -deformation retraction (in the sense of Definition 3.22) onto a subset $K \subseteq W$. Then $p^{-1}(K)$ is a $p^{-1}(F)$ -deformation retract of W' .

Proof The composite map

$$W' \rightarrow W' \times_{p, W, \text{ev}_0} \text{Maps}_F([0, 1], W) \rightarrow \text{Maps}_F([0, 1], W'),$$

where the first map is $w' \mapsto (w', r(p(w')))$ and the second map is the map of Proposition 3.23 is a deformation retraction of W' onto $p^{-1}(K)$. \square

In proving Theorem 4.28, we will have to consider maps which have similar features to the branched covers of Section 3.4.1, except on each stratum they restrict to more general principal bundles. Lemma 3.25 is a slight variant of Corollary 3.24, which works for this larger class of maps as well.

Lemma 3.25 (A slight variant of Corollary 3.24) *Let $p: W_1 \rightarrow W_2$ be a continuous map, and let $K_2 \subseteq W_2$ be a closed deformation retract. Suppose that the restriction $p^{-1}(W_2 \setminus K_2) \rightarrow W_2 \setminus K_2$ is homeomorphic to the projection from a product $F \times (W_2 \setminus K_2) \rightarrow W_2 \setminus K_2$.*

Then $p^{-1}(K_2)$ is a deformation retract of W_1 .

Proof Set $K_1 = p^{-1}(K_2)$. Let us call a path $\gamma: [0, 1] \rightarrow W_2$ a K_2 -constant path if it has the following property: if $\gamma(t) \in K_2$ then $\gamma(s) = \gamma(t)$ for all $s > t$. In other words, once γ enters K_2 , it is constant. Similarly let us define a K_1 -constant path in W_1 if once it enters K_1 , it is constant.

Using the product decomposition of $p^{-1}(W_2 \setminus K_2)$, a K_2 -constant path $\gamma: [0, 1] \rightarrow W_2$ can be lifted in a canonical way to $\tilde{\gamma}: [0, 1] \rightarrow W_1$ once the initial point $\tilde{\gamma}(0)$ is specified, and the assignment

$$W_1 \times \{K_2\text{-constant paths in } W_2\} \rightarrow \{K_1\text{-constant paths in } W_1\}$$

is continuous.

A strong deformation retraction of W_2 onto K_2 is given by $r: W_2 \rightarrow \text{Maps}([0, 1], W_2)$ such that

- $r(w)(0) = w$ for all w ,
- $r(w)(1) \in K_2$ for all w ,
- $r(w)(t) = w$ for all $w \in K_2$ and all t .

For each w , the path $r(w): [0, 1] \rightarrow W_2$ is a K_2 -constant path. Now we may define a map $r_1: W_1 \rightarrow \text{Maps}([0, 1], W_1)$ by the formula

$$r_1(w_1) = \text{lift of } p \circ r_1(w_1) \text{ to } W_2 \text{ with initial point } w_1. \quad \square$$

3.4.2 Retraction onto $\widehat{\partial\Delta}'$

Definition 3.26 The *standard toric filtration* of a toric variety W is the filtration

$$F_0 \subseteq F_1 \subseteq F_2 \subseteq \dots \subseteq W,$$

where each F_i is the union of the torus orbits of dimension i or less.

Proposition 3.27 Let $\tau \subseteq M$ be a lattice simplex, let $\mathbb{P}^{\dim(\tau)}$ be the projective space of Definition 2.12, and let $\mathbb{P}_{\geq 0}^{\dim(\tau)}$ be the nonnegative locus of $\mathbb{P}^{\dim(\tau)}$ in the sense of Definition 3.17. Let ℓ be a homogeneous linear form on $\mathbb{P}^{\dim(\tau)}$ that does not vanish on $\mathbb{P}_{\geq 0}^{\dim(\tau)}$. Let F be the restriction of the standard toric filtration on $\mathbb{P}^{\dim(\tau)}$ to $\mathbb{P}^{\dim(\tau)} \setminus V(\ell)$. Then we have the following.

- (1) There is an F -deformation retraction

$$r: \mathbb{P}^{\dim(\tau)} \setminus V(\ell) \rightarrow \text{Maps}_F([0, 1], \mathbb{P}^{\dim(\tau)} \setminus V(\ell))$$

onto $\mathbb{P}_{\geq 0}^{\dim(\tau)}$.

- (2) We may choose r so that for any face $\tau' \subseteq \tau$, the restriction of r to $\mathbb{P}^{\dim(\tau')}$ is an F' -deformation retraction of $\mathbb{P}^{\dim(\tau')} \setminus V(\ell')$ onto $\mathbb{P}_{\geq 0}^{\dim(\tau')}$. Here ℓ' is the restriction of ℓ to $\mathbb{P}^{\dim(\tau')}$ and F' is the restriction of F to $\mathbb{P}^{\dim(\tau')} \setminus V(\ell')$.

Proof For any two points P, Q in $\mathbb{P}^{\dim(\tau)} \setminus V(\ell) \cong \mathbb{A}^{\dim(\tau)}$, let \overline{PQ} be the real line segment between them. Since each F_i is an affine subspace, if P and Q are in F_i then so is \overline{PQ} . To produce an F -deformation retraction, it is enough to find a map $s: \mathbb{P}^{\dim(\tau)} \setminus V(\ell) \rightarrow \mathbb{P}_{\geq 0}^{\dim(\tau)}$ so that

- $s(P) = P$ for all $P \in \mathbb{P}_{\geq 0}^{\dim(\tau)}$,
- $s(F_i) \subseteq F_i$ for all i .

In that case the map r given by $r(Q) = \overline{Qs(Q)}$ is an F -deformation retraction. A suitable s is given by the moment map of Proposition 3.14, and by Remark 3.16, the deformation retractions we build in this way will have property (2) of the proposition. \square

Theorem 3.28 The inclusion $\widehat{\partial\Delta}' \hookrightarrow X_0$ admits a deformation retraction.

Proof Since $X_{0,\tau} \rightarrow \mathbb{P}^{\dim(\tau)} \setminus V(\ell_\tau)$ is branched along the standard toric filtration of $\mathbb{P}^{\dim(\tau)}$, Proposition 3.27 and Corollary 3.24 together imply that $p_\tau^{-1}(\mathbb{P}_{\geq 0}^{\dim(\tau)})$ is a deformation retract of $X_{0,\tau}$. Moreover by part (2) of Proposition 3.27, these deformation retractions are compatible with inclusions $X_{0,\tau'} \subseteq X_{0,\tau}$. By Remark 3.10, they therefore assemble to a deformation retraction of X_0 to $\widehat{\partial\Delta}'$. \square

4 Log geometry and the Kato–Nakayama space

We recall the definition of a log space X^\dagger from Kato [20] and the associated Kato–Nakayama space X_{\log} from Kato and Nakayama [21] and Nakayama and Ogus [26]. We work with log structures in the analytic topology, which are treated in [21].

4.1 Log structures and log smoothness

For us, a *monoid* is a set with binary operation that is commutative, associative and has a unit. For each monoid M , there is a unique group M^{gp} called the *Grothendieck group of M* together with a map $M \rightarrow M^{\text{gp}}$ satisfying the universal property that every homomorphism from M to a group factors uniquely through $M \rightarrow M^{\text{gp}}$. A monoid is called *integral* if $M \rightarrow M^{\text{gp}}$ is injective. Equivalently, the cancellation law holds in M : $ab = ac \Rightarrow b = c$. A finitely generated and integral monoid is called *fine*. An integral monoid M is called *saturated* if $x \in M^{\text{gp}}$, $x^n \in M$ implies $x \in M$. A finitely generated, saturated monoid is called *toric*.

Example 4.1 If $\sigma \subseteq \mathbb{R}^k$ is a rational polyhedral cone, then $\mathbb{Z}^k \cap \sigma$ is a toric monoid.

Let X be an analytic space. A *pre-log structure* for X is a sheaf of monoids \mathcal{M}_X together with a map of monoids $\alpha_X: \mathcal{M}_X \rightarrow \mathcal{O}_X$ where we use the multiplicative structure for the structure sheaf. We call $(\mathcal{M}_X, \alpha_X)$ a *log structure* if α_X induces an isomorphism on invertible elements $\mathcal{M}_X^\times \xrightarrow{\sim} \mathcal{O}_X^\times$. Given a (pre-)log structure $(\mathcal{M}_X, \alpha_X)$, the triple $X^\dagger = (X, \mathcal{M}_X, \alpha_X)$ is called a (pre-)log space. Pre-log spaces naturally form a category on which we have a forgetful functor to the category of analytic spaces via $X^\dagger \mapsto X$. This functor factors through the category of log spaces by the functor which associates a log structure to a pre-log structure. This is done by replacing $(\mathcal{M}_X, \alpha_X)$ by the *associated log structure* $(\mathcal{M}_X^a, \alpha_X^a)$ given as

$$\mathcal{M}_X^a = (\mathcal{M}_X \oplus \mathcal{O}_X^\times) / \{(m, \alpha_X(m)^{-1}) \mid m \in \mathcal{M}_X^\times = \alpha_X^{-1} \mathcal{O}_X^\times\},$$

with $\alpha_X^a(m, f) = f \cdot \alpha_X(m)$. Most of the time we will omit α_X , assume it as known and refer to a log structure just by its sheaf of monoids.

Example 4.2 If (X, \mathcal{O}_X) is an analytic space, the *trivial log structure* on X is given by $\mathcal{M}_X = (\mathcal{O}_X)^\times$, with α_X the inclusion map.

Example 4.3 If (X, \mathcal{O}_X) is an analytic space and $D \subseteq X$ a divisor, the *divisorial log structure* $\mathcal{M}_{(X,D)}$ on X is given by $\mathcal{M}_{(X,D)} = \mathcal{O}_X \cap j_* \mathcal{O}_{X \setminus D}^\times$, with $j: X \setminus D \rightarrow X$ the open embedding and α_X the inclusion map.

4.1.1 The standard toric log structure on a toric variety Each toric variety W has a natural divisor D which is the complement of the open torus. Thus by [Example 4.3](#), W carries the divisorial log structure $\mathcal{M}_{(W,D)}$ which we call the standard log structure on W . We give another description for it here.

Definition 4.4 A log space (W, \mathcal{M}_W) is called *coherent* if each $x \in W$ has a neighborhood U and a monoid P with a map from the constant sheaf of monoids $P \rightarrow \mathcal{M}_U$ such that the pre-log structure associated to the composition $P \rightarrow \mathcal{M}_U \rightarrow \mathcal{O}_U$ coincides with the log structure \mathcal{M}_U . The data $P \rightarrow \mathcal{M}_U$ is called a *chart* of the log structure on U .

For a coherent log structure, we carry over properties of monoids. For example, we call a coherent log structure *fine* if there exists an open cover $\{U_i\}$ by charts $P_i \rightarrow U_i$ with P_i fine monoids.

If $\sigma \subseteq M_{\mathbb{R}}$ is a rational polyhedral cone then the single chart

$$M \cap \sigma \rightarrow \mathbb{C}[M \cap \sigma]$$

determines a coherent log structure on the affine toric variety $\text{Spec}(\mathbb{C}[M \cap \sigma])$. If W is any toric variety, these assemble to natural log structure on W with charts induced by the canonical maps $\sigma \rightarrow \mathbb{C}[M \cap \sigma]$ for each toric open set $\text{Spec} \mathbb{C}[M \cap \sigma]$ of W . These log structures are fine and saturated. For more see Kato [[19](#), Example 2.6].

Example 4.5 The affine line $\mathbb{A}^1 = \text{Spec}(\mathbb{C}[t])$ has a toric log structure whose chart $\mathbb{Z}_{\geq 0} \rightarrow \mathbb{C}[t]$ is given by $k \mapsto t^k$. If $\mathcal{M}_{\mathbb{A}^1}$ denotes the sheaf of monoids and $U \subseteq \mathbb{A}^1$ is an analytic open subset, then

$$\Gamma(U, \mathcal{M}_{\mathbb{A}^1}) = \begin{cases} \Gamma(U, \mathcal{O}^\times) & \text{if } U \text{ does not contain } 0, \\ \mathbb{Z}_{\geq 0} \oplus \Gamma(U, \mathcal{O}^\times) & \text{if } U \text{ does contain } 0. \end{cases}$$

4.1.2 The log structure on a hypersurface

Definition 4.6 If $u: X \rightarrow Y$ is a map of analytic spaces and \mathcal{M}_Y is a log structure on Y , the *pullback log structure* is defined as the associated log structure to the pre-log structure given by the composition $u^{-1}\mathcal{M}_Y \rightarrow f^{-1}\mathcal{O}_Y \rightarrow \mathcal{O}_X$.

If W is a toric variety and $Z \subseteq W$ is a hypersurface, we may pull back the log structure of [Section 4.1.1](#) along the inclusion map $Z \hookrightarrow W$. The charts of the log structure are of the form

$$M \cap \sigma \rightarrow \mathbb{C}[M \cap \sigma] \rightarrow \mathbb{C}[M \cap \sigma]/f$$

if $f = 0$ is the local equation of Z in the chart $\text{Spec}(\mathbb{C}[M \cap \sigma]) \subseteq W$.

Example 4.7 If $(\mathbb{A}^1, \mathcal{M}_{\mathbb{A}^1})$ is the log affine line of Example 4.5 and $0: \text{Spec } \mathbb{C} \rightarrow \mathbb{A}^1$ is the origin, then the induced log structure on $\text{Spec } \mathbb{C}$ is given by the chart $\mathbb{Z}_{\geq 0} \rightarrow \mathbb{C}$ that carries each $k > 0$ to 0. This is the *standard log point* of [19, Definition 4.3]. We denote it by $\text{Spec } \mathbb{C}^\dagger$. The monoid is $\mathbb{Z}_{\geq 0} \oplus \mathbb{C}^*$.

4.1.3 Log smoothness A map of log spaces is called *smooth* if it satisfies a lifting criterion for log first order thickenings. A log space is smooth if the projection to a point with trivial log structure is smooth. We do not recall the precise definitions here; see [19, Section 3]. A standard argument shows that many of the varieties and maps of Section 2 are log smooth. We record the facts here.

Let $\Gamma_{\geq h}$ and $Y = \text{Spec}(\mathbb{C}[\widetilde{M} \cap \Gamma_{\geq h}])$ be as in Sections 2.1.1 and 2.1.2, and let $\pi: Y \rightarrow \mathbb{A}^1$ be the degeneration of Proposition 2.5. Let $X \subseteq Y$ be the hypersurface of Section 2.2. We endow Y with the log structure of Section 4.1.1 which we denote by \mathcal{M}_Y , \mathbb{A}^1 with the log structure of Example 4.5 which we denote by $\mathcal{M}_{\mathbb{A}^1}$, and X with the log structure of Section 4.1.2 which we denote by \mathcal{M}_X .

The map $\pi: Y \rightarrow \mathbb{A}^1$ upgrades to a map of log spaces $\pi^\dagger: (Y, \mathcal{M}_Y) \rightarrow (\mathbb{A}^1, \mathcal{M}_{\mathbb{A}^1})$ in a unique way. We abuse notation and we will also use π^\dagger for the restriction $(X, \mathcal{M}_X) \rightarrow (\mathbb{A}^1, \mathcal{M}_{\mathbb{A}^1})$.

Lemma 4.8 *The map $\pi^\dagger: (X, \mathcal{M}_X) \rightarrow (\mathbb{A}^1, \mathcal{M}_{\mathbb{A}^1})$ is log smooth.*

Let \bar{Y} and \bar{X} be as in Section 2.3 and furnish them with the log structures of Sections 4.1.1 and 4.1.2. We denote the log structure on \bar{Y} by $\mathcal{M}_{\bar{Y}}$ and the log structure on \bar{X} by $\mathcal{M}_{\bar{X}}$. The maps $\bar{\pi}$ of Section 2.3 upgrade to maps of log spaces $(\bar{Y}, \mathcal{M}_{\bar{Y}}) \rightarrow (\mathbb{A}^1, \mathcal{M}_{\mathbb{A}^1})$ and $(\bar{X}, \mathcal{M}_{\bar{X}}) \rightarrow (\mathbb{A}^1, \mathcal{M}_{\mathbb{A}^1})$. We again abuse notation and denote both of these maps by $\bar{\pi}^\dagger$.

Lemma 4.9 *The map $\bar{\pi}^\dagger: (\bar{X}, \mathcal{M}_{\bar{X}}) \rightarrow (\mathbb{A}^1, \mathcal{M}_{\mathbb{A}^1})$ is log smooth.*

Let \mathcal{M}_{X_0} denote the log structure on X_0 induced by \mathcal{M}_X under the inclusion map $X_0 \hookrightarrow X$. Let $\mathcal{M}_{\bar{X}_0}$ denote the log structure on \bar{X}_0 induced by $\mathcal{M}_{\bar{X}}$ under the inclusion map $\bar{X}_0 \hookrightarrow \bar{X}$. Then we have Cartesian diagrams of log spaces

$$\begin{array}{ccc} (\bar{X}_0, \mathcal{M}_{\bar{X}_0}) & \longrightarrow & (\bar{X}, \mathcal{M}_{\bar{X}}) & & (X_0, \mathcal{M}_{X_0}) & \longrightarrow & (X, \mathcal{M}_X) \\ \downarrow & & \downarrow & & \downarrow & & \downarrow \\ (\text{Spec } \mathbb{C}^\dagger, \mathcal{M}_{\text{Spec } \mathbb{C}^\dagger}) & \longrightarrow & (\mathbb{A}^1, \mathcal{M}_{\mathbb{A}^1}) & & (\text{Spec } \mathbb{C}^\dagger, \mathcal{M}_{\text{Spec } \mathbb{C}^\dagger}) & \longrightarrow & (\mathbb{A}^1, \mathcal{M}_{\mathbb{A}^1}). \end{array}$$

We denote the maps $\bar{X}_0 \rightarrow \text{Spec } \mathbb{C}^\dagger$ and $X_0 \rightarrow \text{Spec } \mathbb{C}^\dagger$ by $\bar{\pi}_0^\dagger$ and π_0^\dagger respectively. We have a similar map $Y_0 \rightarrow \text{Spec } \mathbb{C}^\dagger$, and sometimes we abuse notation and denote it by π_0^\dagger as well.

Lemma 4.10 *The maps π_0^\dagger and $\bar{\pi}_0^\dagger$ are log smooth.*

Remark 4.11 We do not include the proofs of Lemmas 4.8, 4.9 and 4.10 but note that they follow directly from K Kato’s toroidal characterization of log smoothness; see [19, Theorem 4.1].

4.2 The Kato–Nakayama space

Definition 4.12 Let $W^\dagger = (W, \mathcal{M}_X, \alpha_X)$ be a log space. Suppose W^\dagger is coherent in the sense of Definition 4.4. The *Kato–Nakayama space* is the space W_{\log} whose underlying point set is

$$W_{\log} = \left\{ (x, h) \mid x \in W, h \in \text{Hom}(\mathcal{M}_{W,x}^{\text{gp}}, S^1) \text{ and } h(f) = \frac{f(x)}{|f(x)|} \text{ for any } f \in \mathcal{O}_{W,x}^\times \right\},$$

topologized such that whenever $U \subseteq W$ is an open set and $P \rightarrow \mathcal{O}_U$ is a chart, the embedding

$$U_{\log} \hookrightarrow U \times \text{Hom}(P^{\text{gp}}, S^1), \quad (x, h) \mapsto (x, h|_P)$$

is a homeomorphism onto its image. Let $\rho = \rho_{W^\dagger}$ denote the map $W_{\log} \rightarrow W$ given by $\rho(x, h) = x$.

Remark 4.13 The above definition also makes sense when the log structure is not coherent; see [26]. The point set definition is the same and the topology is the weak topology with respect to the functions ρ and $(x, h) \rightarrow h(m)$ for m a local section of \mathcal{M}_W . We will need this more general definition in Section 5.

The map ρ is continuous and surjective, and the construction $W^\dagger \mapsto W_{\log}$ is functorial such that for a morphism $W_1^\dagger \rightarrow W_2^\dagger$, the induced map $W_{1,\log} \rightarrow W_{2,\log}$ is continuous.

Remark 4.14 Define the *K–N log point* $\text{Spec } \mathbb{C}_{KN}^\dagger$ to be the analytic space $\text{Spec } \mathbb{C}$ with the log structure given by $\mathcal{M}_{\text{Spec } \mathbb{C}} = \mathbb{R}_{\geq 0} \times S^1$ and $\alpha_{\text{Spec } \mathbb{C}}: (r, h) \mapsto rh$. Then there is a natural identification of sets

$$W_{\log} = \text{Mor}(\text{Spec } \mathbb{C}_{KN}^\dagger, W^\dagger).$$

Example 4.15 If X carries the trivial log structure, then $X_{\log} = X$.

Example 4.16 Consider the affine line $(\mathbb{A}^1, \mathcal{M}_{\mathbb{A}^1})$ of Example 4.5 and the standard log point $\text{Spec } \mathbb{C}^\dagger$ of Example 4.7. Then $(\mathbb{A}^1)_{\log}$ is homeomorphic to $\mathbb{R}_{\geq 0} \times S^1$, $(\text{Spec } \mathbb{C}^\dagger)_{\log}$ is homeomorphic to S^1 , and the map $\rho: \mathbb{R}_{\geq 0} \times S^1 \rightarrow \mathbb{C}$ is given by $(r, e^{i\theta}) \mapsto r e^{i\theta}$. In other words the map $(\mathbb{A}^1)_{\log} \rightarrow \mathbb{A}^1$ is the real oriented blowup of the origin and $(\text{Spec } \mathbb{C}^\dagger)_{\log}$ is the “exceptional circle” of this blowup.

In general when W is a toric variety and is furnished with the log structure of Section 4.1.1, the space W_{\log} can be described in the manner of Proposition 1.8.

Lemma 4.17 *Let P be a fine, saturated monoid and furnish $W = \text{Spec } \mathbb{C}[P]$ with the log structure given by the natural chart $P \rightarrow \mathcal{O}_W$. Then W_{\log} is naturally identified with $\text{Hom}(P, \mathbb{R}_{\geq 0} \times S^1)$. Moreover, under the identification $W \cong \text{Hom}(P, \mathbb{C})$ of Proposition 1.8, the map $\rho: W_{\log} \rightarrow W$ is given by composing with the monoid epimorphism $\mathbb{R}_{\geq 0} \times S^1 \rightarrow \mathbb{C}$.*

Proof This is [21, Example (1.2.11)]. □

From the description of Definition 4.12 we obtain the following.

Lemma 4.18 *Let (W_1, \mathcal{M}_{W_1}) be a log space, let $W_2 \rightarrow W_1$ be a morphism of complex analytic spaces and let \mathcal{M}_{W_2} be the pullback log structure on W_2 of Definition 4.6. The diagram*

$$\begin{array}{ccc} W_{2,\log} & \longrightarrow & W_2 \\ \downarrow & & \downarrow \\ W_{1,\log} & \longrightarrow & W_1 \end{array}$$

of topological spaces is Cartesian.

4.2.1 The Kato–Nakayama spaces Y_{\log} and $Y_{0,\log}$ Here and in Section 4.2.2, we return to the degeneration of our hypersurface. Here we describe $Y_{0,\log}$, the map $\rho: Y_{0,\log} \rightarrow Y_0$ and its fibers.

Let $\Gamma_{\geq h} \subseteq \widetilde{M}_{\mathbb{R}}$ be the overgraph cone of Section 2.1.1. From Remark 2.4, we can describe Y and Y_0 as spaces of monoid homomorphisms

$$\begin{aligned} Y &= \text{Hom}(\widetilde{M} \cap \Gamma_{\geq h}, \mathbb{C}), \\ Y_0 &= \{\phi \in \text{Hom}(\widetilde{M} \cap \Gamma_{\geq h}, \mathbb{C}) \mid \phi(0, 1) = 0\}. \end{aligned}$$

Then by Lemmas 4.17 and 4.18,

$$\begin{aligned} Y_{\log} &= \text{Hom}(\widetilde{M} \cap \Gamma_{\geq h}, \mathbb{R}_{\geq 0} \times S^1), \\ Y_{0,\log} &= \{\phi \in \text{Hom}(\widetilde{M} \cap \Gamma_{\geq h}, \mathbb{R}_{\geq 0} \times S^1) \mid \phi(0, 1) \in \{0\} \times S^1\}. \end{aligned}$$

4.2.2 The Kato–Nakayama spaces X_{\log} and $X_{0,\log}$ Lemmas 4.17 and 4.18 provide the following description of X_{\log} and $X_{0,\log}$. Let $\Gamma_{\geq h} \subseteq \widetilde{M}_{\mathbb{R}}$ be the overgraph cone of Section 2.1.1. Consider the map

$$Y_{\log} = \text{Hom}(\widetilde{M} \cap \Gamma_{\geq h}, \mathbb{R}_{\geq 0} \times S^1) \rightarrow \text{Hom}(\widetilde{M} \cap \Gamma_{\geq h}, \mathbb{C}) = Y$$

induced by $\mathbb{R}_{\geq 0} \times S^1 \rightarrow \mathbb{C}$. Then X_{\log} and $X_{0,\log}$ are the inverse images under this map of $X \subseteq Y$ and $X_0 \subseteq Y$ respectively. The map $\pi^\dagger: (Y, \mathcal{M}_Y) \rightarrow (\mathbb{A}^1, \mathcal{M}_{\mathbb{A}^1})$ induces commutative diagrams

$$\begin{array}{ccccc}
 Y_{\log} & \longrightarrow & Y & & X_{0,\log} & \longrightarrow & X_0 & & X_{\log} & \longrightarrow & X \\
 \pi_{\log}^\dagger \downarrow & & \downarrow & & (\pi_0^\dagger)_{\log} \downarrow & & \downarrow & & \pi_{\log}^\dagger \downarrow & & \downarrow \\
 \mathbb{A}_{\log}^1 & \longrightarrow & \mathbb{A}^1, & & \mathbb{A}_{\log}^1 & \longrightarrow & \mathbb{A}^1, & & 0_{\log} & \longrightarrow & 0,
 \end{array}$$

where the left vertical maps in the middle and right diagram coincide with the ones induced from the maps in Lemmas 4.8 and 4.10 respectively. We obtain another three such diagrams by replacing Y by \bar{Y} , X by \bar{X} , X_0 by \bar{X}_0 and π by $\bar{\pi}$ respectively. Note that $\mathbb{A}_{\log}^1 = \mathbb{R}_{\geq 0} \times S^1$ and $0_{\log} = \{0\} \times S^1$. Also the diagrams are nested, since each one contains its right neighbor. For a point c in either \mathbb{A}_{\log}^1 or 0_{\log} , we denote its fiber in X_{\log} by $(X_{\log})_c$ and similarly the fiber in \bar{X}_{\log} by $(\bar{X}_{\log})_c$ etc. We will be most interested in the fibers $(X_{0,\log})_1$ and $(\bar{X}_{0,\log})_1$, where 1 refers to the point $(0, 1) \in 0_{\log}$. We have, by definition,

$$\begin{aligned}
 (Y_{\log})_c &= \{\phi \in \text{Hom}(\widetilde{M} \cap \Gamma_{\geq h}, \mathbb{R}_{\geq 0} \times S^1) \mid \phi(0, 1) = c\}, \\
 (X_{\log})_c &= \{\phi \in \text{Hom}(\widetilde{M} \cap \Gamma_{\geq h}, \mathbb{R}_{\geq 0} \times S^1) \mid \phi(0, 1) = c\} \times_Y X.
 \end{aligned}$$

4.3 Embedding the skeleton into the Kato–Nakayama space

In this section we construct an embedding of the skeleton $S_{\Delta, \mathcal{T}} \subseteq \partial\Delta' \times \text{Hom}(M, S^1)$ (Definition 3.1) into the fiber over 1 of the Kato–Nakayama space of the degeneration $(X_{0,\log})_1$; see Section 4.2.2. We will first define a map

$$\lambda: \partial\Delta' \times \text{Hom}(M, S^1) \rightarrow Y_{\log},$$

and then show that λ restricts to an embedding $S_{\Delta, \mathcal{T}} \hookrightarrow (X_{0,\log})_1$. We use the description of Y_{\log} given in Section 4.2.1, ie

$$\begin{aligned}
 Y_{\log} &= \text{Hom}(\widetilde{M} \cap \Gamma_{\geq h}, \mathbb{R}_{\geq 0} \times S^1) \\
 &= \text{Hom}(\widetilde{M} \cap \Gamma_{\geq h}, \mathbb{R}_{\geq 0}) \times \text{Hom}(\widetilde{M} \cap \Gamma_{\geq h}, S^1).
 \end{aligned}$$

Definition 4.19 Let $j: \widehat{\partial\Delta'} \hookrightarrow X_0$ be the embedding of Proposition 3.20, and let us regard $\partial\Delta'$ as a subset of $\widehat{\partial\Delta'}$ by the embedding of Remark 3.11. Define the map $\lambda: \partial\Delta' \times \text{Hom}(M, S^1) \rightarrow Y_{\log}$ by the formula

$$\lambda(x, \phi)(m, r) = (j(x)(m, r), \phi(m)) \in \mathbb{R}_{\geq 0} \times S^1.$$

Remark 4.20 In the definition, we regard $j(x)$ as a homomorphism $\widetilde{M} \cap \Gamma_{\geq h} \rightarrow \mathbb{C}$ in the manner of [Proposition 1.8](#). [Proposition 3.18](#) shows that $j_{\tau,1}$ maps τ homeomorphically onto $(X_{0,\tau})_{\geq 0}$ so in fact $j(x)$ is a homomorphism $\widetilde{M} \cap \Gamma_{\geq h} \rightarrow \mathbb{R}_{\geq 0}$. The monoid homomorphism $j(x)$ has a messy explicit formula. It is given implicitly by the following rules.

- We have $j(x)(m, r) = 0$ unless $r = h(m)$ and $m \in \mathbb{R}_{\geq 0}\tau_x$.
- For $m \in \tau_x^{[0]}$, the values $j(x)(m, h(m))$ are the unique positive real solutions to the following system of equations:

$$(4-1) \quad \sum_{m \in \tau^{[0]}} (j(x)(m, h(m)))^2 m = x \sum_{m \in \tau^{[0]}} (j(x)(m, h(m)))^2$$

$$(4-2) \quad \sum_{m \in \tau^{[0]}} a_m j(x)(m, h(m)) = -a_0$$

The first equation comes from [Proposition 3.14](#) and the second ensures that $j(x) \in X_{0,\tau_x}$.

4.3.1 Properties of the embedding λ

Proposition 4.21 *The image of $\partial\Delta' \times \text{Hom}(M, S^1)$ under λ is contained in $(Y_{0,\log})_1$. The image of $S_{\Delta,\mathcal{T}}$ under λ is contained in $X_{0,\log}$.*

Proof By [Definition 4.19](#) and [Remark 4.20](#), for any $x \in \partial\Delta'$ the homomorphism $j(x)$ carries $(0, 1) \in \Gamma_{\geq h}$ to $0 \in \mathbb{R}_{\geq 0}$. From [Definition 4.19](#), the homomorphism $\lambda(x)$ carries $(0, 1)$ to $(0, 1) \in \mathbb{R}_{\geq 0} \times S^1$. It follows that $\lambda(\partial\Delta' \times \text{Hom}(M, S^1)) \subseteq (Y_{0,\log})_1$.

The map $\lambda(x, \phi): \widetilde{M} \cap \Gamma_{\geq h} \rightarrow \mathbb{R}_{\geq 0} \times S^1$ belongs to $(X_{0,\log})_1 \subseteq (Y_{0,\log})_1$ if and only if

$$(4-3) \quad \sum_{m \in \mathcal{T}^{[0]}} a_m j(x)(m, h(m)) \cdot \phi(m) = -a_0.$$

Since [Remark 4.20](#) $j(x)(m, h(m)) = 0$ unless m belongs to τ_x , the left hand side of (4-3) is

$$\sum_{m \in \tau_x^{[0]}} a_m j(x)(m, h(m)) \phi(m).$$

If (x, ϕ) belongs to $S_{\Delta,\mathcal{T}}$, then $\phi(m) = 1$ for every $m \in \tau_x^{[0]}$, so that this is equal to $-a_0$ by [Remark 4.20](#). □

Proposition 4.22 For each $d \in D_\tau$, let $dA_\tau \subseteq G_\tau$ denote the corresponding coset of A_τ ; see (3-1). Let $r: \text{Hom}(\widetilde{M}, S^1) \rightarrow \text{Hom}(M, S^1)$ denote the restriction map induced by the inclusion $m \mapsto (m, 0)$. Then r induces an isomorphism on the set of homomorphisms $\psi: \widetilde{M} \rightarrow S^1$ obeying the conditions

- (1) $\psi(m, h(m)) = d(m)$ for $m \in \tau$,
- (2) $\psi(0, 1) = 1$,

up to a coset of A_τ .

Proof Because of the second condition, we have that ψ is determined by its values on $M \cong M \times \{0\} \subseteq \widetilde{M}$. If ψ and ψ' obey both conditions, then $\psi/\psi' = 1$ on τ , which characterizes A_τ . □

Theorem 4.23 Let j be the map of Proposition 3.20, and λ the map of Definition 4.19, and let ρ_1 be the map of Definition 4.12. Then the square

$$\begin{array}{ccc}
 S_{\Delta, \mathcal{T}} & \xrightarrow{\lambda} & (X_{0, \log})_1 \\
 \downarrow & & \downarrow \rho_1 \\
 \widehat{\partial\Delta'} & \xrightarrow{j} & X_0
 \end{array}$$

is Cartesian. In particular, $\lambda|_{S_{\Delta, \mathcal{T}}}: S_{\Delta, \mathcal{T}} \rightarrow (X_{0, \log})_1$ is a closed embedding.

Remark 4.24 The above diagram can be used to define $S_{\Delta, \mathcal{T}}$. Replacing $(X_{0, \log})_1$ by $(X_{0, \log})_{e^{i\theta}}$, we obtain a skeleton $S_{\Delta, \mathcal{T}, \theta}$ for any θ . In fact, one may replace $(X_{0, \log})_1$ by $X_{0, \log}$ in order to obtain the entire family of skeleta over S^1 by varying θ . This gives the geometric realization of the monodromy operation of the family $X \rightarrow \mathbb{A}^1$ along a loop around $0 \in \mathbb{A}^1$.

Proof of Theorem 4.23 Fix $(x, d) \in \widehat{\partial\Delta'}$. Thus, $x \in \partial\Delta'$ and d is a homomorphism $M \cap \mathbb{R}_{\geq 0}\tau_x \rightarrow S^1$ carrying the vertices of τ_x to 1. If we regard $j(x)$ as a monoid homomorphism as in Remark 4.20, then $j(x, d)$ is the monoid homomorphism

$$j(x, d)(m, k) = \begin{cases} d(m)j(x)(m, k) & \text{if } k = h(m) \text{ and } m \in \mathbb{R}_{\geq 0}\tau_x, \\ 0 & \text{otherwise.} \end{cases}$$

The fiber of the left vertical map above (x, d) is a coset of A_τ in G_τ . We will show that λ carries this homeomorphically onto the fiber of ρ_1 above $j(x, d)$.

Let $r: \widetilde{M} \cap \Gamma_{\geq h} \rightarrow \mathbb{R}_{\geq 0}$ and $\psi: \widetilde{M} \cap \Gamma_{\geq h} \rightarrow S^1$ be the components of a point $(r, \psi) \in (X_{0, \log})_1 \subseteq Y_{\log}$.

Claim The point (r, ψ) belongs to $\rho_1^{-1}(j(x, d))$ if and only if

- $r(m, k) = 0$ unless $k = h(m)$ and $m \in \mathbb{R}_{\geq 0}\tau_x$,
- $r(m, h(m)) = j(x)(m, h(m))$ when $m \in \mathbb{R}_{\geq 0}\tau_x$,
- $\psi(m, h(m)) = d(m)$ when $m \in \tau_x$ and (because we have restricted ρ to $(X_{0,\log})_1$) $\psi(0, 1) = 1$.

Because of the claim, the fiber $\rho_1^{-1}(j(x, d))$ is naturally parameterized by the set of homomorphisms $\psi: \widetilde{M} \rightarrow S^1$ that obey the third condition on this list, which is a coset of A_τ in G_τ by Proposition 4.22. This agrees with the preimage in $S_{\Delta, \mathcal{T}}$ of (x, d) under λ .

To prove the claim, note that by the definition of j , we have $\rho_1(r, \psi) = j(x, d)$ if and only if the following holds: for all $(m, k) \in \widetilde{M} \cap \Gamma_{\geq h}$,

$$r(m, k)\psi(m, k) = \begin{cases} d(m)j(x)(m, k) & \text{if } k = h(m) \text{ and } m \in \mathbb{R}_{\geq 0}\tau, \\ 0 & \text{otherwise.} \end{cases}$$

In particular we must have $r(m, k) = 0$ unless $k = h(m)$ and $m \in \mathbb{R}_{\geq 0}\tau_x$. In this case

$$r(m, h(m)) = \psi(m, h(m))^{-1}d(m)j(x)(m, h(m)).$$

Since $r(m, h(m))$ and $j(x)(m, k)$ are positive real numbers, $\psi(m, h(m)) = d(m)$. \square

If $\dim \tau_x = n$, then $\rho_1^{-1}(j(x, d)) = A_{\tau_x} = 1$ by the above proof, so we see that we have the following corollary.

Corollary 4.25 Let $(x, d) \in \widehat{\partial\Delta'}$ and suppose $\dim(\tau_x) = n$. Then, in a neighborhood of $j(x, d)$, X_0 is smooth and ρ_1 is an isomorphism.

4.4 The subspace $S_{\Delta, \mathcal{T}}$ is a strong deformation retract

In this section we prove that $S_{\Delta, \mathcal{T}}$ embeds in $(X_{0,\log})_1$ as a strong deformation retract. Recall that Proposition 3.20 and Theorem 3.28, together with Remark 3.16, give the diagram

$$\begin{array}{ccccc} S_{\Delta, \mathcal{T}} & \xrightarrow{\lambda} & (X_{0,\log})_1 & & \\ \downarrow & & \downarrow \rho_1 & \searrow v \circ \rho_1 & \\ \widehat{\partial\Delta'} & \xrightarrow{j} & X_0 & \xrightarrow{v} & \partial\Delta'. \end{array}$$

Lemma 4.26 For each simplex $\tau \subseteq \partial\Delta'$ of \mathcal{T} , let $X_{0,\tau}$ be as in [Definition 2.15](#), let $p_\tau: X_{0,\tau} \rightarrow \mathbb{P}^{\dim(\tau)}$ be as in [Proposition 2.16](#), let $\mu: \mathbb{P}^{\dim(\tau)} \rightarrow \tau$ be the moment map, set $\nu = \mu \circ p_\tau$ and let $\mathbb{P}_{\geq 0}^{\dim(\tau)}$ be the simplex of [Section 3.3.1](#). Each of the following inclusions admits a deformation retraction:

(1) For each $\tau \in \mathcal{T}$, the inclusion

$$p_\tau^{-1}(\mathbb{P}_{\geq 0}^{\dim(\tau)}) \cup \nu_\tau^{-1}(\partial\tau) \hookrightarrow X_{0,\tau}$$

(2) For each $k \leq n$, the inclusion

$$\bigcup_{\tau|\dim(\tau)=k} p_\tau^{-1}(\mathbb{P}_{\geq 0}^{\dim(\tau)}) \cup \nu_\tau^{-1}(\partial\tau) \hookrightarrow \bigcup_{\tau|\dim(\tau)=k} X_{0,\tau}$$

(3) For each $k \leq n$, the inclusion

$$\widehat{\partial\Delta'} \cup \bigcup_{\tau|\dim(\tau)=k} \nu_\tau^{-1}(\partial\tau) \hookrightarrow \widehat{\partial\Delta'} \cup \bigcup_{\tau|\dim(\tau)=k} X_{0,\tau}$$

Before proving the lemma, let us indicate what these spaces are in case Δ is the tetrahedron indicated in [Figure 1](#).

Example 4.27 Let Δ be the tetrahedron with vertices at $(1, 0, 0)$, $(0, 1, 0)$, $(0, 0, 1)$, and $(-1, -1, -1)$ with its unique lattice triangulation \mathcal{T} . For any of the 4 triangles $\tau \in \mathcal{T}$ (the situation is symmetric), the map $p_\tau: X_{0,\tau} \rightarrow \mathbb{P}^{\dim(\tau)}$ is an open embedding. The spaces appearing in [Lemma 4.26\(1\)](#) can be described as follows:

- $X_{0,\tau}$ is, under p_τ , isomorphic to the complement of a line $\ell \subseteq \mathbb{P}^2$ that meets each of the coordinate lines transversely.
- $p_\tau^{-1}(\mathbb{P}_{\geq 0}^{\dim(\tau)})$ is a simplex in $X_{0,\tau}$.
- $\nu_\tau^{-1}(\partial\tau)$ is the union of the three coordinate lines, not including the three points that lie on ℓ .

In fact $p_\tau^{-1}(\mathbb{P}_{\geq 0}^{\dim(\tau)}) \cup \nu_\tau^{-1}(\partial\tau)$ is obtained from the cycle of three affine lines $\nu_\tau^{-1}(\partial\tau)$ by gluing a 2-simplex along a loop that generates the fundamental group of $\nu_\tau^{-1}(\partial\tau)$. In particular this space, like $X_{0,\tau}$ that it is embedded in, is contractible.

Proof of Lemma 4.26 Let us first show $\mathbb{P}_{\geq 0}^{\dim(\tau)} \cup \mu^{-1}(\partial\tau)$ embeds in $\mathbb{P}^{\dim(\tau)} \setminus V(\ell_\tau)$ as a deformation retract. This can be seen as follows. We can write $\mu^{-1}(\partial\tau)$ as the union

$$\mu^{-1}(\partial\tau) = \bigcup_{\tau' \subsetneq \tau} \mathbb{P}^{\dim(\tau')} \setminus V(\ell_{\tau'}).$$

By Proposition 3.27, for any proper face τ' of τ , the space $\mathbb{P}^{\dim(\tau')} \setminus V(\ell_{\tau'})$ deformation retracts onto $\mathbb{P}_{\geq 0}^{\dim(\tau')} \subseteq \mathbb{P}_{\geq 0}^{\dim(\tau)}$ in a way that is compatible with the inclusions of smaller strata. This gives a deformation retraction

$$\mu^{-1}(\partial\tau) \rightarrow \partial(\mathbb{P}_{\geq 0}^{\dim(\tau)})$$

that can be extended to a deformation retraction

$$\mathbb{P}_{\geq 0}^{\dim(\tau)} \cup \mu^{-1}(\partial\tau) \rightarrow \mathbb{P}_{\geq 0}^{\dim(\tau)}$$

by defining it to be the identity on $\mathbb{P}_{\geq 0}^{\dim(\tau)}$. Since $\mathbb{P}_{\geq 0}^{\dim(\tau)}$ is contractible, this implies that $\mathbb{P}_{\geq 0}^{\dim(\tau)} \cup \mu^{-1}(\partial\tau)$ is contractible as well.

The existence of a deformation retraction $\mathbb{P}^{\dim(\tau)} \setminus V(\ell_{\tau}) \rightarrow \mathbb{P}_{\geq 0}^{\dim(\tau)} \cup \mu^{-1}(\partial\tau)$ is then a consequence of standard facts about CW complexes: any contractible subcomplex of a contractible CW complex is a strong deformation retract; see eg McCammond [24, Lemma 1.6]. Claim (1) can be proved by applying Lemma 3.25 to p_{τ} . In fact, by Proposition 2.16(3), $p_{\tau}: X_{0,\tau} \rightarrow \mathbb{P}^{\dim(\tau)} \setminus V(\ell_{\tau})$ is unramified away from $\mathbb{P}_{\geq 0}^{\dim(\tau)} \cup \mu^{-1}(\partial\tau)$.

We turn now to claim (2). Note that for any pair of distinct k -dimensional simplices τ_1, τ_2 , $X_{0,\tau_1} \cap X_{0,\tau_2} = v_{\tau_1}^{-1}(\partial\tau_1) \cap v_{\tau_2}^{-1}(\partial\tau_2)$. As a consequence, the retractions defined in (1) agree on the intersections of the various components: in fact, they restrict to the identity there. This guarantees that they assemble to give a retraction of $\bigcup_{\dim(\tau)=k} X_{0,\tau}$ onto $\bigcup_{\dim(\tau)=k} (p_{\tau}^{-1}(\mathbb{P}_{\geq 0}^{\dim(\tau)}) \cup (\mu_{\tau} \circ p_{\tau})^{-1}(\partial\tau))$, as desired. The last claim follows from the observation that

$$\widehat{\partial\Delta'} \cap \bigcup_{\dim(\tau)=k} X_{0,\tau} \subseteq \bigcup_{\dim(\tau)=k} p_{\tau}^{-1}(\mathbb{P}_{\geq 0}^{\dim(\tau)}) \cup v_{\tau}^{-1}(\partial\tau).$$

Thus, the retraction obtained in (2) can be extended to $\widehat{\partial\Delta'} \cup \bigcup_{\dim(\tau)=k} X_{0,\tau}$, by setting it equal to the identity on $\widehat{\partial\Delta'}$. \square

Theorem 4.28 *The subspace $S_{\Delta,\mathcal{T}}$ embeds in $(X_{0,\log})_1$ as a strong deformation retract.*

Proof Let $\partial\Delta'_i$ be the $(n-i)$ -skeleton of the stratification of $\partial\Delta'$ given by \mathcal{T} , ie set $\partial\Delta'_i := \bigsqcup_{\tau \in \mathcal{T}, \dim \tau \leq n-i} \tau^{\circ}$. Note that $v^{-1}(\partial\Delta'_i) = \bigcup_{\dim(\tau)=n-i} X_{0,\tau}$. Set $(S_{\Delta,\mathcal{T}})_i := S_{\Delta,\mathcal{T}} \cup (v \circ \rho_1)^{-1}(\partial\Delta'_i)$. Then if $i \leq i'$, we have the inclusion $(S_{\Delta,\mathcal{T}})_{i'} \subseteq (S_{\Delta,\mathcal{T}})_i$. Also, we have that $(S_{\Delta,\mathcal{T}})_0 = (X_{0,\log})_1$, and $(S_{\Delta,\mathcal{T}})_i = S_{\Delta,\mathcal{T}}$ for $i \geq n$. Thus, the theorem can be restated as saying that $(S_{\Delta,\mathcal{T}})_n$ embeds in $(S_{\Delta,\mathcal{T}})_0$ as a deformation retract.¹ We prove this by induction on i : namely, we show that for each

¹Note that for all $i \geq n$ $(S_{\Delta,\mathcal{T}})_i = S_{\Delta,\mathcal{T}}$.

$i \geq 0$, $(S_{\Delta, \mathcal{T}})_i$ retracts onto $(S_{\Delta, \mathcal{T}})_{i+1}$. The theorem follows by composing all these retractions.

We start with the step $i = 0$. Applying Lemma 4.26(3), with k equal to $n - 1$, we obtain a retraction of X_0 onto $\widehat{\partial\Delta}' \cup v^{-1}(\partial\Delta'_1)$. By Corollary 4.25, ρ_1 is a homeomorphism over $X_0 - v^{-1}(\partial\Delta'_1)$, and in particular over $X_0 - (\widehat{\partial\Delta}' \cup v^{-1}(\partial\Delta'_1))$. Corollary 3.24 then implies that the space

$$\rho_1^{-1}(\widehat{\partial\Delta}' \cup v^{-1}(\partial\Delta'_1)) = S_{\Delta, \mathcal{T}} \cup (v \circ \rho_1)^{-1}(\partial\Delta'_1) = (S_{\Delta, \mathcal{T}})_1$$

embeds in $(X_{0, \log})_1 = (S_{\Delta, \mathcal{T}})_0$ as a deformation retract.

Next, we prove the inductive hypothesis. By Lemma 4.26(2), we have that $v^{-1}(\partial\Delta'_i) = \bigcup_{\dim(\tau)=n-i} X_{0, \tau}$ retracts onto

$$v^{-1}(\partial\Delta'_{i+1}) \cup \bigcup_{\dim(\tau)=n-i} p_{\tau}^{-1}(\mathbb{P}_{\geq 0}^{\dim(\tau)}).$$

Also, for all τ , ρ_1 restricts to a projection from a product with fiber A_{τ} over $v^{-1}(\tau^{\circ})$; see the proof of Theorem 4.23. Thus we can apply Lemma 3.25 in the following way: using the notation of Lemma 3.25, set $W_1 = (v \circ \rho_1)^{-1}(\partial\Delta'_i)$, $W_2 = (v)^{-1}(\partial\Delta'_i)$, $p = \rho_1|_{W_1}$ and

$$K_2 = v^{-1}(\partial\Delta'_{i+1}) \cup \bigcup_{\dim(\tau)=n-i} p_{\tau}^{-1}(\mathbb{P}_{\geq 0}^{\dim(\tau)}).$$

This gives a retraction of $(v \circ \rho_1)^{-1}(\partial\Delta'_i)$ onto

$$(v \circ \rho_1)^{-1}(\partial\Delta'_{i+1}) \cup \bigcup_{\dim(\tau)=n-i} (p_{\tau} \circ \rho_1)^{-1}(\mathbb{P}_{\geq 0}^{\dim(\tau)}).$$

Note that $S_{\Delta, \mathcal{T}} \cap (v \circ \rho_1)^{-1}(\partial\Delta'_i)$ is contained in the latter. This follows from the proof of Lemma 4.26(3), observing that $S_{\Delta, \mathcal{T}} = \rho_1^{-1}(\widehat{\partial\Delta}')$, while

$$(v \circ \rho_1)^{-1}(\partial\Delta'_i) = \rho_1^{-1} \left(\bigcup_{\dim(\tau)=n-i} X_{0, \tau} \right).$$

Thus, in the usual manner, we can extend the retraction constructed in the previous paragraph to a retraction of $(S_{\Delta, \mathcal{T}})_i = S_{\Delta, \mathcal{T}} \cup (v \circ \rho_1)^{-1}(\partial\Delta'_i)$ onto $(S_{\Delta, \mathcal{T}})_{i+1} = S_{\Delta, \mathcal{T}} \cup (v \circ \rho_1)^{-1}(\partial\Delta'_{i+1})$, by setting it equal to the identity on $S_{\Delta, \mathcal{T}}$. This concludes the proof. \square

4.5 Proof of Theorem 1.2

We wish to relate the affine hypersurface $Z \cong X_1$ to the special fiber of the Kato–Nakayama space $(X_{0,\log})_1$. In fact these spaces are homeomorphic, as we now show by proving that the Kato–Nakayama space is a fiber bundle. Together with Theorem 4.28, this establishes the Theorem 1.2 of the introduction.

We wish to show that the map $\pi_{\log}: X_{\log} \rightarrow \mathbb{R}_{\geq 0} \times S^1$ is a topological fiber bundle. Since X_{\log} is not endowed with a smooth structure, and the fibers of π_{\log} are not compact, this is not straightforward to check. However the relative compactification $\bar{\pi}: \bar{X} \rightarrow \mathbb{A}^1$ considered in Section 2.3 admits a natural log structure, and the map $\bar{\pi}_{\log}: \bar{X}_{\log} \rightarrow \mathbb{R}_{\geq 0} \times S^1$ is proper. We can check that $\bar{\pi}$ is a fiber bundle whose fibers are manifolds with boundary with the “relative rounding theory” of Nakayama and Ogus. For this, we introduce further notions: recall that in [26], a morphism of monoids $\theta: P \rightarrow Q$ is called *vertical* if the image of P is not contained in any proper face of Q . The morphism is *exact* if the diagram

$$\begin{array}{ccc} P & \longrightarrow & Q \\ \downarrow & & \downarrow \\ P^{\text{gp}} & \longrightarrow & Q^{\text{gp}} \end{array}$$

is Cartesian. A morphism $(W_1, \mathcal{M}_1) \rightarrow (W_2, \mathcal{M}_2)$ of log spaces is called *vertical at* $x \in W_1$ (resp. *exact at* $x \in W_1$) if the induced map of monoids $\mathcal{M}_{2,f(x)} \rightarrow \mathcal{M}_{1,x}$ is vertical (resp. exact.) The relevant result for us is the following.

Theorem 4.29 (Nakayama–Ogus) *Let W^\dagger be a fine log space, let $(\mathbb{A}^1)^\dagger$ be the affine line with the log structure of Example 4.5, and let $f: W^\dagger \rightarrow (\mathbb{A}^1)^\dagger$ be a morphism of fine log spaces. If f is proper, separated, and log smooth, then the map $f_{\log}: W_{\log} \rightarrow \mathbb{R}_{\geq 0} \times S^1$ is a topological fiber bundle.*

Proof In order to deduce this from [26, Theorem 5.1], we need to show that f is exact, ie the map $f^{-1}\mathcal{M}_{\mathbb{A}^1,y} \rightarrow \mathcal{M}_{W,x}$ is exact whenever $f(x) = y$. This is straightforward when $y \neq 0$ since then $\mathcal{M}_{\mathbb{A}^1,y} = \mathcal{O}_{\mathbb{A}^1,y}^\times$, so assume $y = 0$. Since $\mathcal{M}_{\mathbb{A}^1,0}/\mathcal{M}_{\mathbb{A}^1,0}^\times \cong \mathbb{Z}_{\geq 0}$, the only thing to check is that a lift of a generator of $\mathbb{Z}_{\geq 0}$ maps to a noninvertible element in $\mathcal{M}_{W,x}$. This follows directly from properness as such a generator is a coordinate on the base \mathbb{A}^1 . □

Recall that an n -dimensional topological manifold with boundary is a topological space locally homeomorphic to either \mathbb{R}^n or $\mathbb{R}^{n-1} \times \mathbb{R}_{\geq 0}$. If W is a topological manifold with boundary write W° for the interior, ie the set of points with a neighborhood homeomorphic to \mathbb{R}^n , and ∂W for the complement of W° .

Proposition 4.30 (1) *The spaces \bar{X}_{\log} as well as $(\bar{X}_{\log})_c$ for each $c \in \mathbb{A}_{\log}^1$ are topological manifolds with boundary.*

(2) *For each $c \in \mathbb{R}_{\geq 0} \times S^1$, the interior of the fiber $(\bar{X}_{\log})_c$ is precisely $(X_{\log})_c$.*

Proof We have log smoothness of the maps in consideration by Lemma 4.8 and 4.9. Moreover, it is not hard to see that the maps are exact. Under these conditions, by [26, Theorem 3.5], the fibers are manifolds with boundary and boundary points coincide with nonvertical points. Thus, the proposition is a consequence of the following claim:

A point of \bar{X} is vertical for the map $\bar{\pi}^\dagger$ if and only if it belongs to $X \subseteq \bar{X}$.

Indeed, recalling that $\mathbb{Z}_{\geq 0}$ gives a chart on the base, we just need to check where the generator of $\mathbb{Z}_{\geq 0}$ gets mapped into a proper face of a stalk of the log structures upstairs and this is precisely in $\bar{X} \setminus X$. □

Corollary 4.31 *The map $\bar{\pi}_{\log}: \bar{X}_{\log} \rightarrow \mathbb{A}_{\log}^1$ is a topological fiber bundle.*

Proof Both $\bar{X}^\dagger, (\mathbb{A}^1)^\dagger$ are fine log spaces. The map $\bar{\pi}$ is proper, separated and exact by Theorem 4.29. Log smoothness is given by Lemma 4.10. □

Corollary 4.32 *The map $\pi_{\log}: X_{\log} \rightarrow \mathbb{A}_{\log}^1$ is a topological fiber bundle.*

In particular, we have that $(X_{0,\log})_1$ is homeomorphic to the hypersurface $Z = V(f)$. By Theorem 4.28, $(X_{0,\log})_1$ deformation retracts to $S_{\Delta,\mathcal{T}}$. Therefore, so does Z . We have thus proven the Theorem 1.2 of the introduction.

5 Hypersurfaces in affine toric varieties

We now consider a generalization of our setting and our theorem to address the case where $Z = f^{-1}(0)$ is a smooth hypersurface in a general affine toric variety A . Such an A contains a dense algebraic torus T and by Theorem 4.28 we already have a skeleton S for $Z \cap T$ upon fixing the origin and a triangulation of the Newton polytope of f . It turns out that a skeleton for Z itself can be given as a topological quotient space of S , so partial compactification translates into taking a quotient in terms of skeleta. This is what we are going to prove in this section.

Example 5.1 As a simple example of this more general setting, we can consider the polynomial $f: \mathbb{C}^2 \rightarrow \mathbb{C}, f(x, y) = x^2 + xy + y^2 - 1$, that we discussed in Examples 2.7, 2.14 and 3.5. We let $A = \mathbb{C}^2$, and note that $A = \text{Spec}(\mathbb{C}[K \cap M])$, where $K = \mathbb{R}_{\geq 0}^2 \subseteq \mathbb{R}^2$ is a convex, maximal-dimensional cone. In Example 5.7 we will work out the geometry of the zero locus of f in A , and explicitly describe a skeleton for it.

5.1 The general setup

Let $M \cong \mathbb{Z}^{n+1}$ be a lattice. Let $M_{\mathbb{R}} := M \otimes_{\mathbb{Z}} \mathbb{R} \cong \mathbb{R}^{n+1}$. Let $K \subseteq M_{\mathbb{R}}$ be an $(n + 1)$ -dimensional, convex rational polyhedral cone. Then $M \cap K$ is a finitely generated monoid and $A := \text{Spec}(\mathbb{C}[M \cap K])$ is an affine toric variety. The smallest torus orbit in A is $\text{Spec}(\mathbb{C}[M \cap K^\times])$, where K^\times denotes the maximal linear subspace contained in K . We set $a = \dim K^\times$ and $b = n + 1 - a$. Consider the projection $M \rightarrow M/(M \cap K^\times)$ and its real analog $p_{K^\times}: M_{\mathbb{R}} \rightarrow M_{\mathbb{R}}/K^\times$. We set $\bar{K} = p_{K^\times}(K)$ and have

$$A \cong \text{Spec}(\mathbb{C}[M \cap K^\times]) \times \text{Spec} \mathbb{C}[\bar{K} \cap (M/(M \cap K^\times))]$$

and the first factor is a -dimensional and the second b -dimensional.

Remark 5.2 Note that A is smooth if and only if $(K, M_{\mathbb{R}}, M)$ is isomorphic to $(\mathbb{R}^a \times \mathbb{R}_{\geq 0}^b, \mathbb{R}^{a+b}, \mathbb{Z}^{a+b})$.

Let $f \in \mathbb{C}[M \cap K]$ be a regular function on A , and let Δ be the Newton polytope of f and $Z := f^{-1}(0) \subseteq A$. We make the following assumptions.

- Assumption 5.3**
- (1) A is either smooth or has at most an isolated singularity. Note that the latter implies that $b = 0$, if A is singular.
 - (2) We have $\dim \Delta = \dim K$.
 - (3) We have $\bar{K} = \mathbb{R}_{\geq 0} p_{K^\times}(\Delta)$, so Δ generates the cone K up to invertible elements.
 - (4) The hypersurface Z is smooth.

- Remark 5.4**
- (1) We necessarily have $\Delta \subseteq K$. By assumption (4) above, we have $\Delta + K^\times$ contains 0 . We may thus assume without loss of generality that $0 \in \Delta$ by multiplying f with a suitable invertible element if necessary (leaving Z unchanged).
 - (2) Note that if assumption (2) above is violated then Z splits as a product $Z_1 \times Z_2$ where $\dim Z_1 = \dim \Delta$, Z_1 has the same Newton polytope as Z and Z_2 is isomorphic to $(\mathbb{C}^*)^{a'} \times \mathbb{C}^{b'}$ for suitable a', b' . Since $(S^1)^{a'}$ is a skeleton for $(\mathbb{C}^*)^{a'} \times \mathbb{C}^{b'}$, imposing assumption (2) loses no generality.
 - (3) In the case where A is smooth, note that assumption (3) above can always be achieved by a linear coordinate transformation of A .

Example 5.5 Let $M = \mathbb{Z}^{n+1}$. If $K = M_{\mathbb{R}}$, then $A = (\mathbb{C}^*)^{n+1}$. If $a + b = n + 1$ and $K = \mathbb{R}^a \times \mathbb{R}_{\geq 0}^b$, then $A = (\mathbb{C}^*)^a \times \mathbb{C}^b$. For an example of a singular ambient variety, take $n = 1$ and put $K = \{x \geq |y|\} \subseteq \mathbb{R}^2$. Then $A = \mathbb{C}^2/\mathbb{Z}_2$.

As in Equation (2-1), we assume that Δ is equipped with a lattice triangulation \mathcal{T}_Δ and that

$$(5-1) \quad f = a_0 + \sum_{m \in \mathcal{T}^{[0]}} a_m z^m.$$

As for the previous sections, we assume $0 \in \mathcal{T}_\Delta^{[0]}$, $a_0 \in \mathbb{R}_{<0}$ and $a_m \in \mathbb{R}_{>0}$ for $m \neq 0$ and that these coefficients are generic in the sense of Remark 1.7. We also assume to have a convex piecewise linear function $h: \mathbb{R}_{\geq 0} \Delta \rightarrow \mathbb{R}$ taking nonnegative integral values on M such that the maximal-dimensional simplices in \mathcal{T}_Δ coincide with the nonextendable closed domains of linearity of $h|_\Delta$.

5.2 The general definition of the skeleton

As before, let \mathcal{T} denote the subset of \mathcal{T}_Δ of the cells not containing 0. Let $\partial\Delta'$ denote the union of the cells in \mathcal{T} and for $x \in \partial\Delta'$, let τ_x denote the smallest cell of \mathcal{T} containing x . Recall $S_{\Delta, \mathcal{T}}$ from Definition 3.1

$$S_{\Delta, \mathcal{T}} = \{(x, \phi) \in \partial\Delta' \times \text{Hom}(M, S^1) \mid \phi(v) = 1 \text{ whenever } v \text{ is a vertex of } \tau_x\}.$$

For $x \in K$, we denote by K_x the smallest face of K containing x .

Definition 5.6 Let $S_{\Delta, \mathcal{T}, K}$ denote the quotient of $S_{\Delta, \mathcal{T}}$ by the equivalence relation \sim given by

$$(x, \phi) \sim (x', \phi') \quad \text{if and only if } x = x' \text{ and } \phi|_{K_x \cap M} = \phi'|_{K_x \cap M}.$$

The goal is to show that $S_{\Delta, \mathcal{T}, K}$ embeds in Z as a deformation retract.

Example 5.7 Let us go back to the setup of Example 5.1. Recall that we have $K = \mathbb{R}_{\geq 0}^2$. Then $S_{\Delta, \mathcal{T}, K}$ is a quotient of $S_{\Delta, \mathcal{T}}$ as in Definition 5.6. The quotient is only nontrivial for $x = b$ and $x = e$. For $x = b$, K_x is the x -axis, and therefore $\beta \sim \beta'$ in $G_{\{b\}}$ (see Example 3.5), meaning the two circles are contracted to two points. The same happens when $x = e$. As a result, four of the five circles in the bouquet that is $S_{\Delta, \mathcal{T}}$ are contracted, and $S_{\Delta, \mathcal{T}, K}$ is homotopy equivalent to a single circle.

As a reality check, we give an explicit description of the geometry of this hypersurface, and verify that it does have the expected homotopy type. Solving for y in the equation $x^2 + xy + y^2 = 1$, presents the solution space as a branched cover of the x -plane with two branch points $x = \pm 2/\sqrt{3}$. That space retracts to a two to one cover of the line segment between the points, branched at the ends: a circle. From this analysis it becomes clear that the restriction of the hypersurface to the algebraic torus $(\mathbb{C}^*)^2$

removes the four points $(0, \pm 1)$ and $(\pm 1, 0)$, which up to homotopy adds four circles to the hypersurface. This confirms that the calculation of the skeleton $S_{\Delta, \mathcal{T}}$ contained in [Example 3.5](#) is correct.

5.3 Construction of the ambient degeneration

The construction of the degeneration in the general case is not different from the previous. For completeness, we repeat it here. Recall the notation $\tilde{M} = M \oplus \mathbb{Z}$, $\tilde{M}_{\mathbb{R}} = \tilde{M} \otimes_{\mathbb{Z}} \mathbb{R}$. As in [Section 2.3](#), we define the noncompact polyhedron

$$\bar{\Gamma} = \{(m, r) \mid m \in \Delta, r \geq h(m)\} \subseteq \tilde{M}_{\mathbb{R}}$$

and \bar{Y} be the toric variety given by the normal fan of $\bar{\Gamma}$. We may set $\Gamma_{\geq h} = \mathbb{R}_{\geq 0} \bar{\Gamma}$ and find the affine chart

$$Y = \text{Spec } \mathbb{C}[\Gamma_{\geq h} \cap \tilde{M}]$$

on which we have the two regular functions $t = z^{(0,1)}$ and $\tilde{f} = \sum_{m \in \Delta} a_m z^{(m, h(m))}$. In fact, t extends to a regular function on \bar{Y} . Let $X = V(\tilde{f})$ denote the affine hypersurface cut out by \tilde{f} in Y and let \bar{X} denote its closure in \bar{Y} . We restrict t to a regular function on \bar{X} .

The following lemma elucidates the relation between $\bar{\Gamma}$ and K .

Lemma 5.8 *We have an inclusion preserving bijection*

$$\{\text{faces of } \bar{\Gamma} \text{ containing } \bar{\Gamma} \cap (K^{\times} \times \mathbb{R})\} \longleftrightarrow \{\text{faces of } K\}$$

by sending a face G on the left-hand side to $(\mathbb{R}_{\geq 0} G + (K^{\times} \times \mathbb{R})) \cap M_{\mathbb{R}}$ on the right.

Proof Faces of K are in inclusion-preserving bijection with faces of $K \times \mathbb{R}$ and the latter coincides with the localization $\bar{\Gamma} + (K^{\times} \times \mathbb{R})$ of $\bar{\Gamma}$ by [Assumption 5.3\(3\)](#). \square

5.4 The nonstandard log structure

Let D denote the complement of the open torus in \bar{Y} . Then D is a toric divisor in \bar{Y} . In [Section 4](#), we used the standard toric log structure $\mathcal{M}_{\bar{Y}} = \mathcal{M}_{(\bar{Y}, D)}$ on the toric variety \bar{Y} ([Section 4.1.1](#)), which eventually led to an embedding of $S_{\Delta, \mathcal{T}} \subseteq (\bar{Y}_{0, \log})_1$ as a deformation retract. To indicate that \bar{Y}_{\log} is defined using the log structure $\mathcal{M}_{\bar{Y}}$, we denote it from now on by $\bar{Y}(\mathcal{M}_{\bar{Y}})_{\log}$.

We now construct another log structure $\mathcal{F}_{\bar{Y}}$ on \bar{Y} . For this we specify a reduced toric divisor $D_{\mathcal{F}} \subseteq \bar{Y}$, ie $D_{\mathcal{F}} \subseteq D$, and we then define $\mathcal{F}_{\bar{Y}}$ as the divisorial log structure with respect to $D_{\mathcal{F}}$. Recall that the components of D correspond to the facets of $\bar{\Gamma}$. To define $D_{\mathcal{F}}$, we need to pick a subset of these facets.

Definition 5.9 We let $D_{\mathcal{F}} \subseteq \bar{Y}$ be the reduced toric divisor whose components correspond to the facets of $\bar{\Gamma}$ that do not contain the face $(K^{\times} \times \mathbb{R}) \cap \bar{\Gamma}$ and define $\mathcal{F}_{\bar{Y}} = \mathcal{M}_{(\bar{Y}, D_{\mathcal{F}})}$.

We want to describe the stalks of $\mathcal{F}_{\bar{Y}}$ explicitly. Let F_1, \dots, F_r be an enumeration of the facets of $\bar{\Gamma}$ containing $(K^{\times} \times \mathbb{R}) \cap \bar{\Gamma}$. For a face $G \subseteq \bar{\Gamma}$, we denote by $\langle G, F_i \rangle$ the smallest face of $\bar{\Gamma}$ containing G and F_i , ie

$$\langle G, F_i \rangle = \begin{cases} F_i & \text{if } G \subseteq F_i, \\ \bar{\Gamma} & \text{otherwise.} \end{cases}$$

We define $F_G := \bigcap_{i=1}^r \langle G, F_i \rangle$. For faces $G_1, G_2 \subseteq \bar{\Gamma}$ with $G_1 \subseteq G_2$, we have $F_{G_1} \subseteq F_{G_2}$.

Lemma 5.10 We have $F_G = \bigcap_{G \subseteq F_i} F_i = \langle \bar{\Gamma} \cap (K^{\times} \times \mathbb{R}), G \rangle$.

We can now identify the stalks of $\mathcal{F}_{\bar{Y}}$.

Lemma 5.11 Let $y \in \bar{Y}$ be a point and $G \subseteq \bar{\Gamma}$ be the face that corresponds to the torus orbit that contains y . We have

$$\mathcal{F}_{\bar{Y}, y} = (\tilde{M} \cap \mathbb{R}_{\geq 0}(F_G - G)) \otimes_{(\tilde{M} \cap \mathbb{R}_{\geq 0}(F_G - G))^{\times}} \mathcal{O}_{\bar{Y}, y}^{\times}$$

and this is a face of

$$\mathcal{M}_{\bar{Y}, y} = (\tilde{M} \cap \mathbb{R}_{\geq 0}(\bar{\Gamma} - G)) \otimes_{(\tilde{M} \cap \mathbb{R}_{\geq 0}(\bar{\Gamma} - G))^{\times}} \mathcal{O}_{\bar{Y}, y}^{\times}.$$

Proof On the chart $\tilde{M} \cap \mathbb{R}_{\geq 0}(\bar{\Gamma} - G) \rightarrow \mathbb{C}[\tilde{M} \cap \mathbb{R}_{\geq 0}(\bar{\Gamma} - G)]$ of the log structure $\mathcal{M}_{\bar{Y}}$, the subsheaf $\mathcal{F}_{\bar{Y}}$ up to invertible elements is generated by the those monomials that do not vanish on the divisors corresponding to F_1, \dots, F_r , ie precisely the monomials contained in $\mathbb{R}_{\geq 0}(F_G - G)$. Moreover, we have that $\mathbb{R}_{\geq 0}(F_G - G)$ is clearly a face of $\mathbb{R}_{\geq 0}(\bar{\Gamma} - G)$. \square

The log structure $\mathcal{F}_{\bar{Y}}$ will in general not be coherent. However we have the following replacement.

Proposition 5.12 The log structure $\mathcal{F}_{\bar{Y}}$ is relatively coherent in $\mathcal{M}_{\bar{Y}}$ in the sense of [26, Definition 3.6.1].

Proof This just states that $\mathcal{F}_{\bar{Y}}$ is a sheaf of faces in $\mathcal{M}_{\bar{Y}}$ which is Lemma 5.11. \square

Let $\mathcal{F}_{\bar{X}}$ (resp. $\mathcal{M}_{\bar{X}}$) denote the pullback of the log structure $\mathcal{F}_{\bar{Y}}$ (resp. $\mathcal{M}_{\bar{Y}}$) to \bar{X} .

Corollary 5.13 *The log structure $\mathcal{F}_{\bar{X}}$ is relatively coherent in $\mathcal{M}_{\bar{X}}$.*

5.5 Relative log smoothness

Note that $t = z^{(0,1)}$ is a global section of $\mathcal{F}_{\bar{Y}}$ since all F_i contain $(0, 1)$. Thus, by mapping the generator of $\mathbb{Z}_{\geq 0}$ to t , we obtain a map of log spaces $\bar{\pi}^\dagger: (\bar{Y}, \mathcal{F}_{\bar{Y}}) \rightarrow (\mathbb{A}^1, \mathcal{M}_{\mathbb{A}^1})$. Moreover, we have that the inclusion $\mathcal{F}_{\bar{Y}} \subseteq \mathcal{M}_{\bar{Y}}$ induces a map $g^{\bar{Y}}$ so that we have the sequence of maps of log spaces

$$(\bar{Y}, \mathcal{M}_{\bar{Y}}) \xrightarrow{g^{\bar{Y}}} (\bar{Y}, \mathcal{F}_{\bar{Y}}) \xrightarrow{\bar{\pi}^\dagger} (\mathbb{A}^1, \mathcal{M}_{\mathbb{A}^1})$$

and we know that the composition $\bar{\pi}^\dagger \circ g^{\bar{Y}}$ is log smooth by an analogue of Lemma 4.9 for \bar{Y} . Recall from [26, Definition 3.6,2] the definition of a relatively log smooth map.

Lemma 5.14 *If A is smooth, then the map $\bar{\pi}^\dagger$ is relatively log smooth. If A is not smooth, then $\bar{\pi}^\dagger$ is relatively log smooth away from the closure of the torus orbit in \bar{Y} corresponding to $(0 \times \mathbb{R}) \cap \bar{\Gamma}$.*

Proof It remains to show that the stalks of $\mathcal{M}_{\bar{Y}}/\mathcal{F}_{\bar{Y}}$ are free monoids at points for which we claim the map to be relatively log smooth. Let $y \in \bar{Y}$ be a point in a torus orbit corresponding to a face $G \subseteq \bar{\Gamma}$. By Lemma 5.11, we have $\mathcal{M}_{\bar{Y},y}/\mathcal{F}_{\bar{Y},y} = (\tilde{\mathcal{M}} \cap \mathbb{R}_{\geq 0}(\bar{\Gamma} - G))/(\tilde{\mathcal{M}} \cap \mathbb{R}_{\geq 0}(F_G - G))$ and we need to show that this is isomorphic to $\mathbb{Z}_{\geq 0}^s$ for some s . This is equivalent to saying that \bar{Y} is smooth in a neighborhood of the torus orbit corresponding to the smallest face of $\bar{\Gamma}$ that contains F_G and G . It suffices to show that for any subset $I \subseteq \{1, \dots, r\}$, Y is smooth in a neighborhood of the torus orbit corresponding to $F_I := \Gamma_{\geq h} \cap \bigcap_{i \in I} F_i$, except for the case where $F_I = \{0\} \times \mathbb{R}_{\geq 0}$ because we make no claim for this by the restrictions made in the assertion in the lemma. Note that since F_I contains $(K^\times \times \mathbb{R}) \cap \Gamma_{\geq h}$, the torus orbit corresponding to F_I is contained in the open subset $A \times \mathbb{C}^*$ of \bar{Y} , so the statement follows from the smoothness of A in codimension one. \square

Note that we also have a sequence of log spaces

$$(\bar{X}, \mathcal{M}_{\bar{X}}) \xrightarrow{g^{\bar{X}}} (\bar{X}, \mathcal{F}_{\bar{X}}) \xrightarrow{\bar{\pi}^\dagger} (\mathbb{A}^1, \mathcal{M}_{\mathbb{A}^1}),$$

where we abuse notation by denoting the second map as $\bar{\pi}^\dagger$ again. Again, we know that the composition $g^{\bar{X}} \circ \bar{\pi}^\dagger$ is log smooth by Lemma 4.9. When A is singular, note that \bar{X} is disjoint from the torus orbit in \bar{Y} corresponding to $(0 \times \mathbb{R}) \cap \bar{\Gamma}$, so using Assumption 5.3(4), we conclude the following.

Lemma 5.15 *The map $\bar{\pi}^\dagger: (\bar{X}, \mathcal{F}_{\bar{X}}) \rightarrow (\mathbb{A}^1, \mathcal{M}_{\mathbb{A}^1})$ is relatively log smooth.*

5.6 The Kato–Nakayama space is a fiber bundle

By Remark 4.13, we may construct the Kato–Nakayama space for $(\bar{Y}, \mathcal{F}_{\bar{Y}})$ and $(\bar{X}, \mathcal{F}_{\bar{X}})$ and by functoriality, we have maps

$$\begin{aligned} \bar{Y}(\mathcal{M}_{\bar{Y}})_{\log} &\xrightarrow{g_{\log}^{\bar{Y}}} \bar{Y}(\mathcal{F}_{\bar{Y}})_{\log} \xrightarrow{\bar{\pi}_{\log}^{\dagger}} \mathbb{A}_{\log}^1, \\ \bar{X}(\mathcal{M}_{\bar{X}})_{\log} &\xrightarrow{g_{\log}^{\bar{X}}} \bar{X}(\mathcal{F}_{\bar{X}})_{\log} \xrightarrow{\bar{\pi}_{\log}^{\dagger}} \mathbb{A}_{\log}^1. \end{aligned}$$

The statement of Theorem 5.1 in [26] allows for the weaker assumption of relative coherency of the source and relatively smoothness of the map, so we conclude from Lemma 5.15 along the same lines as in Section 4.5 the following result.

Theorem 5.16 *The maps of Kato–Nakayama spaces*

$$\bar{X}(\mathcal{F}_{\bar{X}})_{\log} \xrightarrow{\bar{\pi}_{\log}^{\dagger}} \mathbb{A}_{\log}^1 \quad \text{and} \quad \bar{X}(\mathcal{M}_{\bar{X}})_{\log} \xrightarrow{\bar{\pi}_{\log}^{\dagger} \circ g_{\log}^{\bar{X}}} \mathbb{A}_{\log}^1,$$

are topological fiber bundles.

The statement of Proposition 4.30 also holds word for word after replacing \bar{X}_{\log} and X_{\log} by $\bar{X}(\mathcal{F}_{\bar{X}})_{\log}$ and $X(\mathcal{F}_X)_{\log}$, where \mathcal{F}_X is the restriction of $\mathcal{F}_{\bar{X}}$ to X .

5.7 Embedding $S_{\Delta, \mathcal{T}, K}$ in the Kato–Nakayama space $(\bar{X}(\mathcal{F}_{\bar{X}})_{\log})_1$

We use the notation

$$\begin{array}{ccc} \bar{Y}(\mathcal{M}_{\bar{Y}})_{\log} & \xrightarrow{g_{\log}^{\bar{Y}}} & \bar{Y}(\mathcal{F}_{\bar{Y}})_{\log} \\ & \searrow \rho(\mathcal{M}_{\bar{Y}}) & \downarrow \rho(\mathcal{F}_{\bar{Y}}) \\ & & \bar{Y} \end{array}$$

for the induced maps on Kato–Nakayama spaces (similarly for X, \bar{X} in place of Y, \bar{Y}).

Proposition 5.17 *Given a point $y \in \bar{Y}$ contained in the torus orbit associated to the face $G \subseteq \bar{\Gamma}$, the map $g_{\log}|_{\rho(\mathcal{M}_{\bar{Y}})^{-1}(y)}: \rho(\mathcal{M}_{\bar{Y}})^{-1}(y) \rightarrow \rho(\mathcal{F}_{\bar{Y}})^{-1}(y)$ is the restriction map*

$$\text{Hom}\left(\frac{\tilde{M} \cap \mathbb{R}_{\geq 0}(\bar{\Gamma} - G)}{\tilde{M} \cap \mathbb{R}(G - G)}, S^1\right) \rightarrow \text{Hom}\left(\frac{\tilde{M} \cap \mathbb{R}_{\geq 0}(F_G - G)}{\tilde{M} \cap \mathbb{R}(G - G)}, S^1\right)$$

induced by the injection

$$\frac{\tilde{M} \cap \mathbb{R}_{\geq 0}(F_G - G)}{\tilde{M} \cap \mathbb{R}(G - G)} \hookrightarrow \frac{\tilde{M} \cap \mathbb{R}_{\geq 0}(\bar{\Gamma} - G)}{\tilde{M} \cap \mathbb{R}(G - G)}.$$

Proof This is a straightforward combination of [Definition 4.12](#) and [Lemma 5.11](#) with the additional observation that $(\mathbb{R}_{\geq 0}(\bar{\Gamma} - G))^\times = (\mathbb{R}_{\geq 0}(F_G - G))^\times = \mathbb{R}(G - G)$. \square

As before, we denote by $(\bar{X}(\mathcal{F}_{\bar{X}})_{\log})_1$ the fiber of $g_{\log}^{\bar{X}}$ over $(0, 1) \in \mathbb{R}_{\geq 0} \times S^1 = \mathbb{A}_{\log}^1$. There is a surjection

$$g_{\log}^{\bar{X}}: \bar{X}(\mathcal{M}_{\bar{X}})_{\log,1} \rightarrow \bar{X}(\mathcal{F}_{\bar{X}})_{\log,1}.$$

Theorem 5.18 *We have a canonical embedding of $S_{\Delta, \mathcal{T}}$ in $\bar{X}(\mathcal{M}_{\bar{X}})_{\log,1}$ whose image under $g_{\log}^{\bar{X}}$ is canonically identified with $S_{\Delta, \mathcal{T}, \mathcal{K}}$.*

Proof We have the result of [Theorem 4.23](#) already, so in particular an embedding of $\widehat{\partial\Delta'}$ in \bar{X} and of $S_{\Delta, \mathcal{T}}$ in $(\bar{X}(\mathcal{M}_{\bar{X}})_{\log})_1$. We need to show that the image of $S_{\Delta, \mathcal{T}}$ under $g_{\log}^{\bar{X}}$ yields the quotient space $S_{\Delta, \mathcal{T}, \mathcal{K}}$. We fix a point $x \in \bar{X}$ in a torus orbit $O_G = \text{Spec } \mathbb{C}[\mathbb{R}(G - G) \cap \widetilde{M}]$ with $G \subseteq \bar{\Gamma}$. Let us regard the composition

$$\bar{X}(\mathcal{M}_{\bar{X}})_{\log,1} \xrightarrow{g_{\log}^{\bar{X}}} \bar{X}(\mathcal{F}_{\bar{X}})_{\log,1} \xrightarrow{\rho(\mathcal{F}_{\bar{X}})} \bar{X}.$$

By the Cartesian property of the Kato–Nakayama space in [Lemma 4.18](#), we may use [Proposition 5.17](#) to identify the restriction of $g_{\log}^{\bar{X}}$ to the inverse images of x as the map $T_1 \rightarrow T_2$, where

$$T_1 = \left\{ \alpha \in \text{Hom} \left(\frac{\widetilde{M} \cap \mathbb{R}_{\geq 0}(\bar{\Gamma} - G)}{\widetilde{M} \cap \mathbb{R}(G - G)}, S^1 \right) \mid \alpha(0, 1) = 1 \right\},$$

$$T_2 = \left\{ \alpha \in \text{Hom} \left(\frac{\widetilde{M} \cap \mathbb{R}_{\geq 0}(F_G - G)}{\widetilde{M} \cap \mathbb{R}(G - G)}, S^1 \right) \mid \alpha(0, 1) = 1 \right\}.$$

Let $p: \widetilde{M}_{\mathbb{R}} \rightarrow M_{\mathbb{R}}$ denote the natural projection and K_G denote the smallest face of K containing $p(G)$. We have $p(\bar{\Gamma}) = \Delta$. We use the fact that the condition $\alpha(0, 1) = 1$ in T_1, T_2 can be replaced by changing the source of α to a subquotient of M instead of \widetilde{M} . Precisely,

$$T_1 = \text{Hom} \left(\frac{M \cap \mathbb{R}_{\geq 0}(\Delta - p(G))}{M \cap p(\mathbb{R}(G - G))}, S^1 \right),$$

$$T_2 = \text{Hom} \left(\frac{M \cap \mathbb{R}_{\geq 0}(p(F_G) - p(G))}{M \cap p(\mathbb{R}(G - G))}, S^1 \right).$$

Note that if $x \in \widehat{\partial\Delta'}$ then K_G coincides with K_x . Moreover, F_G contains $(K^\times \times \mathbb{R}) \cap \bar{\Gamma}$ and thus corresponds to the face $(\mathbb{R}_{\geq 0}F_G + K^\times \times \mathbb{R}) \cap M_{\mathbb{R}}$ of K by [Lemma 5.8](#). We claim that this face is K_G . Indeed by [Lemma 5.10](#), F_G is the smallest face of $\bar{\Gamma}$ containing G and $\bar{\Gamma} \cap K^\times \times \mathbb{R}$ which maps to $K_{p(G)}$ under the bijection in [Lemma 5.8](#). Finally, we may assume that G contains $\bar{\Gamma} \cap (K^\times \times \mathbb{R})$ because otherwise $F_G = \bar{\Gamma}$

and $K_G = K$ and this case is clear. Note that $\tau_x := p(G) \cap \partial\Delta'$ is an element of \mathcal{T} . We can then identify

$$T_1 = A_{\tau_x}, \quad T_2 = \text{Hom}\left(\frac{M \cap K_G}{M \cap K_G^\times}, S^1\right),$$

which gives the desired quotient representation of $g_{\log}^{\bar{X}}(\rho(\mathcal{M}_{\bar{X}})^{-1}(x))$ as given in Definition 5.6. \square

5.8 Retraction

Theorem 5.19 (Main Theorem for general cones) *The skeleton $S_{\Delta, \mathcal{T}, K}$ embeds in Z as a strong deformation retract.*

Proof By Theorem 5.18, we have an embedding $j: S_{\Delta, \mathcal{T}, K} \hookrightarrow (\bar{X}(\mathcal{F}_{\bar{X}})_{\log})_1$ and by Theorem 5.16 a homeomorphism $Z \cong (\bar{X}_{\log})_1$. It remains to show that j is a strong deformation retraction. This works in precisely the same way as the argument of Theorem 4.28. From the proof of Theorem 5.18 above, we have an explicit description of the fibers of the map $\rho(\mathcal{F}_{\bar{X}})$ over a point $x \in \widehat{\partial\Delta'}$ and these are “constant” on the interiors of the simplices of \mathcal{T} . This allows us to use Lemma 3.25 to lift retractions and construct an inductive argument exactly as in Theorem 4.28. \square

References

- [1] **M Abouzaid**, *Homogeneous coordinate rings and mirror symmetry for toric varieties*, *Geom. Topol.* 10 (2006) 1097–1157 [MR2240909](#)
- [2] **M Abouzaid**, *Symplectic perspectives on tropical geometry* (2009) talk given at MSRI Introductory workshop: Tropical geometry Available at <http://www.msri.org/workshops/481/schedules/3811>
- [3] **M Abouzaid, D Auroux, L Katzarkov**, *Lagrangian fibrations on blowups of toric varieties and mirror symmetry for hypersurfaces* [arXiv:1205.0053](#)
- [4] **A Andreotti, T Frankel**, *The Lefschetz theorem on hyperplane sections*, *Ann. of Math.* 69 (1959) 713–717 [MR0177422](#)
- [5] **V V Batyrev**, *Variations of the mixed Hodge structure of affine hypersurfaces in algebraic tori*, *Duke Math. J.* 69 (1993) 349–409 [MR1203231](#)
- [6] **V G Berkovich**, *Smooth p -adic analytic spaces are locally contractible, II*, from: “Geometric aspects of Dwork theory, Vol. I, II”, (A Adolphson, F Baldassarri, P Berthelot, N Katz, F Loeser, editors), de Gruyter (2004) 293–370 [MR2023293](#)

- [7] **H Bruggesser, P Mani**, *Shellable decompositions of cells and spheres*, Math. Scand. 29 (1971) 197–205 [MR0328944](#)
- [8] **K Cieliebak, Y Eliashberg**, *Symplectic geometry of Stein manifolds*, in preparation
- [9] **V I Danilov, A G Khovanskii**, *Newton polyhedra and an algorithm for calculating Hodge–Deligne numbers*, Izv. Akad. Nauk SSSR Ser. Mat. 50 (1986) 925–945 [MR873655](#) In Russian; translated in Math. USSR Izvestiya 29 (1987) 279–298
- [10] **P Deligne**, *Hodge cycles on abelian varieties*, from: “Hodge cycles, motives, and Shimura varieties”, Lecture Notes in Math. 900 (1982) 9–100
- [11] **B Fang, C-C M Liu, D Treumann, E Zaslow**, *The coherent–constructible correspondence for toric Deligne–Mumford stacks* [arXiv:0911.4711](#)
- [12] **B Fang, C-C M Liu, D Treumann, E Zaslow**, *A categorification of Morelli’s theorem*, Invent. Math. 186 (2011) 79–114 [MR2836052](#)
- [13] **RH Fox**, *Covering spaces with singularities*, from: “A symposium in honor of S Lefschetz”, Princeton Univ. Press (1957) 243–257 [MR0123298](#)
- [14] **W Fulton**, *Introduction to toric varieties*, Annals of Mathematics Studies 131, Princeton Univ. Press (1993) [MR1234037](#)
- [15] **IM Gelfand, MM Kapranov, A V Zelevinsky**, *Discriminants, resultants, and multi-dimensional determinants*, Birkhäuser, Boston (1994) [MR1264417](#)
- [16] **M Gross, L Katzarkov, H Ruddat**, *Towards mirror symmetry for varieties of general type* [arXiv:1202.4042](#)
- [17] **M Gross, B Siebert**, *From real affine geometry to complex geometry*, Ann. of Math. 174 (2011) 1301–1428 [MR2846484](#)
- [18] **A Hatcher**, *Algebraic topology*, Cambridge Univ. Press (2002) [MR1867354](#)
- [19] **F Kato**, *Log smooth deformation theory*, Tohoku Math. J. 48 (1996) 317–354 [MR1404507](#)
- [20] **K Kato**, *Logarithmic structures of Fontaine–Illusie*, from: “Algebraic analysis, geometry, and number theory”, (J-I Igusa, editor), Johns Hopkins Univ. Press, Baltimore, MD (1989) 191–224 [MR1463703](#)
- [21] **K Kato, C Nakayama**, *Log Betti cohomology, log étale cohomology, and log de Rham cohomology of log schemes over \mathbb{C}* , Kodai Math. J. 22 (1999) 161–186 [MR1700591](#)
- [22] **M Kontsevich, Y Soibelman**, *Affine structures and non-Archimedean analytic spaces*, from: “The unity of mathematics”, (P Etingof, V Retakh, IM Singer, editors), Progr. Math. 244, Birkhäuser, Boston (2006) 321–385 [MR2181810](#)
- [23] **D Kozlov**, *Combinatorial algebraic topology*, Algorithms and Computation in Mathematics 21, Springer, Berlin (2008) [MR2361455](#)

- [24] **J P McCammond**, *A general small cancellation theory*, Internat. J. Algebra Comput. 10 (2000) 1–172 [MR1752738](#)
- [25] **G Mikhalkin**, *Decomposition into pairs-of-pants for complex algebraic hypersurfaces*, Topology 43 (2004) 1035–1065 [MR2079993](#)
- [26] **C Nakayama, A Ogus**, *Relative rounding in toric and logarithmic geometry*, Geom. Topol. 14 (2010) 2189–2241 [MR2740645](#)
- [27] **H Ruddat**, *Log Hodge groups on a toric Calabi–Yau degeneration*, from: “Mirror symmetry and tropical geometry”, (R Castaño-Bernard, Y Soibelman, I Zharkov, editors), Contemp. Math. 527, Amer. Math. Soc. (2010) 113–164 [MR2681794](#)
- [28] **N Sibilla, D Treumann, E Zaslow**, *Ribbon graphs and mirror symmetry, I* [arXiv:1103.2462](#)
- [29] **D Treumann, E Zaslow**, *Polytopes and skeleta* [arXiv:1109.4430](#)
- [30] **J Woolf**, *The fundamental category of a stratified space*, J. Homotopy Relat. Struct. 4 (2009) 359–387 [MR2591969](#)

Mathematisches Institut, Johannes Gutenberg-Universität Mainz
Staudingerweg 9, D-55099 Mainz, Germany

Max Planck Institute for Mathematics
Vivatsgasse 7, D-53111 Bonn, Germany

Department of Mathematics, Boston College
Carney Hall, Room 301, Chestnut Hill, Boston, MA 02467-3806, USA

Department of Mathematics, Northwestern University
2033 Sheridan Road, Evanston, IL 60208-2730, USA

ruddat@uni-mainz.de, nicolo.sibi@gmail.com, davidtreumann@gmail.com,
zaslow@math.northwestern.edu

Proposed: Richard Thomas
Seconded: Benson Farb, Danny Calegari

Received: 11 July 2013
Revised: 19 December 2013

